

**Analysis of the Toxicity Hazards of Methylene Chloride Associated  
with the Use of Tear Gas at the Branch Davidian Compound at  
Waco, Texas on April 19, 1993**

Prepared for

The Office of Special Counsel  
John C. Danforth

By

Dr. George Lucier

Pittsboro, North Carolina

September 15, 2000

## Table of Contents

Executive Summary.....	2
Chemical Properties.....	5
Production and Use.....	5
Federal and State Regulations.....	6
Health Effects.....	7
Death.....	9
Neurological Effects.....	9
Absorption and Metabolism of Inhaled MC.....	10
Role of Metabolism in Neurotoxicity.....	12
Physiological-Based Pharmacokinetic (PBPK) Models for.....	13
Estimating the Amounts and Fate of Methylene Chloride In the Branch Davidians on April 19, 1993	
PBPK Models are Commonly Used in Risk Assessment.....	13
PBPK Models for MC.....	14
Application of PBPK Models for MC Exposures.....	15
to Adults and Children Inside the Branch Davidian Complex	
Relevance of Predicted MC and COHb.....	20
MC Concentrations in Remains of the Branch Davidians.....	24
Experiments in Rats.....	25
Experiment 1.....	26
Experiment 2.....	27
Experiment 3.....	28
Avoidance/Escape Learning Procedures.....	29
for Rats Used in Experiments 4 and 5	
Experiments 4 and 5 - Active Avoidance Testing.....	30
General Conclusions.....	31
General References.....	33
Appendix A - Tables 1-20. Results from methylene chloride simulations for each room; Time of peak MC concentration in blood, blood MC at peak, blood MC at 12:20 p.m.	
Appendix B - Figures 1-14. MC air concentrations, MC blood concentrations, CO in blood and percentage COHb from 6:00 a.m. to 12:20 p.m. for different exposure scenarios	
Appendix C - Andersen ME, Clewell, HJ, Gargas ML et al. (Physiologically-based pharmacokinetic modeling with dichloromethane, its metabolite carbon monoxide and blood carboxyhemoglobin in rats and humans. Toxicol Appl Pharmacol 108:14-27 (1991).	
Appendix D - Credentials and curriculum vitae of George W. Lucier	

## **Executive Summary**

The Office of the Special Counsel retained me in December of 1999 to provide a toxicological evaluation of the possible effects of the methylene chloride (MC) exposures to the Branch Davidians inside the Waco Compound on April 19, 1993. MC exposures occurred as a consequence of its use as a solvent for solid CS in the tear gas ferret rounds and canisters. Specifically, I was asked to investigate the following two questions:

- ◆ Did the MC exposures inside the Waco Compound kill any of the Branch Davidians on April 19, 1993?
- ◆ Did the MC exposures inside the Compound significantly impair the judgment of the Branch Davidians such that they were unable to escape the fire on April 19, 1993?

My approach to this task was several fold involving:

- ◆ Analysis of the scientific literature for health effects and toxicity of MC in humans and experimental animals. Since MC is a commonly used solvent in many industrial settings, there is a wealth of scientific literature available as well as the existence of numerous risk assessments made by Federal and State regulatory agencies. Rigorous analysis of the existing literature was not done in previous investigations.
- ◆ Analysis of the remains of the Branch Davidians for residues of MC. This was not done in previous investigations.
- ◆ Predictions of the uptake and retention of MC following various exposure scenarios for April 19, 1993. The predictions employed existing physiologically-based pharmacokinetic (PBPK) models for MC and were based on the MC exposure estimates made by Dr. Jerry Havens using information supplied by the Office of Special Counsel on the number and timing of tear gas ferret rounds fired (386) and canisters inserted (20) into the complex on April 19, 1993.

PBPK models predict the behavior of MC and its breakdown products inside the body and have not been used in any previous analysis of possible toxicities caused by MC exposures encountered by the Branch Davidians. PBPK models are a commonly used tool in risk assessments made by Federal and State agencies as well as other organizations.

- ◆ Experiments were conducted in rats to determine if the carbon monoxide (CO) produced from MC inside the human body could render the animals less able to avoid or escape from an electric shock. When trapped in a fire people often asphyxiate from high carbon monoxide exposures. Because MC

exposure also produces CO in the blood, it was important to determine whether MC exposure prior to a fire could have possibly rendered some individuals inside the Compound less capable of escaping from the fire. Such experiments were not conducted in previous investigations.

Careful evaluation of the results of this strategy leads me to make the following conclusions:

1. MC exposures did not kill any of the Branch Davidians on April 19, 1993. The highest blood concentrations predicted from a worst case exposure scenario was 65 mg/L. This compares to the range of blood MC concentrations in cases of fatal MC poisoning of 281-700 mg/L.
2. MC is a central nervous system (CNS) depressant and this effect appears to be the most sensitive response following MC exposures of less than one day. Based on evaluation of several possible exposure scenarios and the application of PBPK models to the relevant data it is likely that some of the Branch Davidians experienced some form of CNS depression. This effect on CNS function could have led to decreased responsiveness to visual or auditory signals, irritation or dizziness. The mechanism for this response could possibly have been a direct effect of MC on the CNS or less likely oxygen deprivation from CO produced by MC degradation inside the body. Blood concentrations of 2-12 mg/L MC have been reported to cause mild CNS depression and higher blood levels of MC were likely experienced by some of the Branch Davidians at some point during the morning of April 19, 1993.
3. Children would likely be slightly more sensitive to a given air MC concentration than adults because of physiological differences between adults and children including the fact that children breathe faster than adults.
4. It is possible that exposure to MC during the morning of April 19, 1993 caused a few of the Branch Davidians to become unconscious from smoke inhalation slightly earlier than they would have if MC exposures had not occurred. Controlled testing provided evidence against this possibility as rats administered low levels of CO (mimicking MC metabolism to CO) followed by much higher CO exposures (mimicking fire exposure) exhibited the same or better escape reactions than rats receiving only the high CO exposure.
5. The Branch Davidians were exposed to a mixture of chemicals (CS, MC and their metabolites) on April 19, 1993. Exposure to such mixtures raises some concerns because little is known regarding the toxicological consequences of exposure to complex mixtures.

I was retained by the Office of Special Counsel in December of 1999 while I was employed by the National Institute of Environmental Health Sciences (NIEHS), one of the National Institutes of Health which is administered by the U.S. Department of Health

and Human Services. On December 7, 1999, I requested and received permission to assist the Office of Special Counsel as part of my official duties with the understanding that I would not give information to or discuss the investigation with any government officials. My position at the NIEHS had two parts. One as a senior scientist and the other as Director of the Environmental Toxicology Program. In that capacity, I was responsible for coordinating the National Toxicology Program (NTP) generally considered the world's most comprehensive toxicology research and testing program. It's charged with providing toxicological evaluations on substances of public health concern. I retired from the NIEHS on June 30, 2000, after 30 years of service. My written report was prepared after I left government service.

## Chemical Properties

Methylene Chloride (MC) is a halogenated aliphatic hydrocarbon, a widely used class of chemicals. It is also known as dichloromethane and its structure is shown below

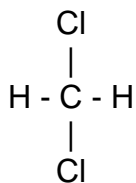

MC is a colorless liquid with a boiling point of 39.8°C. It is generally considered nonflammable and non-explosive.

MC has a number of trade names including Narkotil, Solaesthin and Solmethine. It has many identification numbers as indicated below:

Chemical Abstract Service	75-09-2
National Institute of Occupational Safety and Health Registry of Toxic Effects of Chemical Substances	PA 8050000
Environmental Protection Agency Hazardous Waste	U080F002
Oil and Hazardous Materials/ Technical Assistance Data System	7217234
Department of Transportation/ United Nations/North America/ International Maritime Dangerous Goods Code	UN1593,IMCD6.1
Hazardous Substances Data Bank	66
National Cancer Institute	C50102

## Production and Use

MC is produced by the chlorination of methane with chlorine or by the chlorination of methanol with hydrogen chloride. Production of MC grew steadily through the 1970's and early 1980's with a peak production of about 620 million pounds in 1984. Since then there has been a small but steady drop in production. There are currently 867 facilities that produce or process MC in the United States including 41 in Texas.

MC is used as a solvent in paint strippers and removers, as a propellant in aerosols, as a process solvent in the manufacture of drugs, pharmaceuticals, and film coatings, as a metal cleaning and finishing solvent and in foam production. Aerosol products in which MC can be found include paints, automotive products and insect sprays. However, because of labeling regulations and concerns over health and environmental issues, the use of MC in consumer aerosol products has declined. MC was once used in hair sprays but the FDA banned this use in 1989. MC had been used extensively to remove caffeine from coffee, however because of concern over health risks; most decaffeinator no longer use MC. In any event, use of MC as a solvent in tear gas canisters and ferret rounds is a minor use of this commercially important solvent.

MC has been detected in ambient air samples taken from around the world. Background levels are usually about 50 parts per trillion ( $0.17 \mu\text{g}/\text{m}^3$ ) (Singh, 1982). Concentrations in some urban areas and in the vicinity of hazardous waste sites are generally 10-100 times higher. These values are all much lower than the concentrations found inside buildings and in workplaces where MC is used.

### **Federal and State Regulations**

Because of its widespread use Federal and State agencies have developed regulations for allowable levels in the workplace and general environment. Permissible levels in the workplace are generally far greater than those allowed in the general environment.

The Occupational Safety and Health Administration (OSHA) recently conducted a quantitative risk assessment (1998) for MC exposure in the workplace. Based on this assessment OSHA requires employers to keep exposure levels at or below 25 ppm ( $88 \text{ mg}/\text{m}^3$ ) averaged over an 8-hour workday. Respirators must be used in circumstances where this level is exceeded. The OSHA regulation is based on central nervous system effects following short and long term exposures and cancer effects following long term or chronic exposures. EPA has calculated a reference concentration (i.e. safe exposure level) of  $3\text{-mg}/\text{m}^3$  (1 ppm) based on a two-year inhalation study in rats, which did not detect adverse effects at or below 200 ppm. The Agency for Toxic Substances Disease Registry (ATSDR) established a short-term safe exposure level of 3 ppm and 0.3 ppm for long term exposures. In addition, a number of states have set acceptable ambient air concentration at the fence line of industrial facilities. Some current Federal and state regulations are indicated below:

OSHA	Maximum Peak for 8 hour	25 ppm
EPA	Safe Exposure Level (Chronic)	1 ppm
Massachusetts	Acceptable Ambient Level	0.0008 ppm
New York	Acceptable Ambient Level	0.009 ppm

North Carolina	Acceptable Ambient Level	0.008 ppm
Washington State		0.007 ppm

These regulations employ a large margin of safety and can be considered a virtually safe dose for breathing MC over a lifetime. Most states allow much higher levels for short-term exposures than for lifetime exposures.

**Health Effects**

There have been a number of studies that have examined health effects from MC exposure. These studies have examined adverse effects in people exposed to MC vapors in the workplace and in animals exposed to varying amounts of MC administered by varying routes (i.e. inhalation, ingestion or skin contact). Some of the studies evaluated effects arising from long term exposures (months or years) while others evaluated shorter-term exposures (one day or less). Information on the shorter-term exposures is, of course, most relevant to the situation for the Branch Davidians in Waco on April 19, 1993 so I will focus on those effects in my evaluation. For example, there have been several studies that have determined that MC exposures at high lifetime concentrations (> 3000 mg/m<sup>3</sup>) causes cancer in rodents. The chances that exposure to high concentrations of MC for one day would cause cancer is remarkably close to 0. In the very remote probability that such exposure did cause cancer, this cancer would not become clinically detectable for at least 10 years. The U.S. Department of Health and Human Services has classified MC as "Reasonably anticipated to be a human carcinogen" and the World Health Organization classifies it as a possible human carcinogen. Although cancer effects of MC in people exposed occupationally or environmentally has been a highly controversial issue in regulating decision making by agencies such as OSHA, EPA, CPSC and FDA) it is of little concern regarding use of MC as a solvent in tear gas in riot control or crowd control situations.

There are publications in the scientific literature that have evaluated a number of non-cancer effects of MC and these are summarized below. These are of more interest to the Waco investigation.

<u>Organ or System Evaluated</u>	<u>Findings</u>
Death	High exposures for 4 hrs (> 17,000 ppm) can cause death in experimental animals and people
Neurological	Mild effects on central nervous system function by doses as low as 200 ppm for 4 hrs or 300 ppm for 1.5 hrs in workers.



	More severe effects such as unconsciousness occur at high exposures (about 10,000 ppm/ 4 hrs)
Cardiovascular	Very high exposures (10,000 - 30,000 ppm) might cause cardiac arrhythmias based on studies in animals but no such effects have been detected in people exposed to MC occupationally.
Respiratory	High exposures (8400 ppm for 13 weeks) caused lung inflammation in rodents. The clara cells of the lung appear to be sensitive to MC. Irritative symptoms of the respiratory tract have been observed in people using large amounts of MC-based solvents.
Gastrointestinal	No reported effect of MC
Hematologic	Elevated carboxyhemoglobin levels following occupational exposures to MC which diminishes oxygen carrying capacity of red blood cells. This could cause unconsciousness and possibly death following very high exposures and could exacerbate existing cardiac conditions.
Liver	No reported effects of MC in humans although chronic exposure to MC causes liver damage in rodents.
Kidney Effects	No reported effects in people although mild kidney damage seen in rats exposed to MC for 100 days.
Immune Effects	No reported effects in people although some spleen effects were observed in rats and dogs after chronic exposure.
Reproductive and Developmental Effects	One study reported low sperm counts in MC-exposed workers however extensive studies in experimental animals did not detect effects on

reproduction or development.

Based on the above summary, the health endpoints of interest for the Waco investigation are death, unconsciousness and central nervous system effects because these effects can occur following short-term exposures (6 hrs or less) to sufficiently high concentrations of MC. Each of these endpoints is discussed in more detail in the following narrative.

### Death

There are several case studies in the scientific literature, which clearly demonstrate that MC can be fatal to humans when large amounts are used in poorly ventilated areas. The most common cases of fatal poisonings have occurred in paint stripping operations. Other cases of death occurred in metal cleaning operations, in workers burying barrels containing MC, and cleaning of underground storage tanks with MC-based solvents.

The air concentrations of MC that caused death was not reported or estimated in most cases. However, these were all very high exposures and in some cases may have been over 100,000 ppm for several hours. Information from rodent studies indicates that 16,000 - 19,000 ppm MC for several hours is fatal to rats and mice. These same studies indicated that there is a narrow margin between the concentrations that cause unconsciousness and death. For example, no deaths occurred in mice exposed to 16,800 ppm for 4 hrs although all mice were unconscious. In contrast, 70% of mice died when exposed to 17,250 ppm for 4 hrs.

One way of comparing MC exposures that are known to have been fatal to exposures that occurred in Waco, is to compare blood levels of MC across several studies. In the case of MC-caused fatalities blood concentrations have ranged from 281 mg/L to 710 mg/L although blood MC measurements were not made in most fatal cases. Unfortunately, I could not find any cases where blood MC measurements were quantified in individuals who were rendered unconscious by MC and did not die. Since the exposure level required to cause unconsciousness is roughly 1/2 that required to cause death, it is reasonable to assume that blood concentrations of greater than 100 mg/L would be required to cause unconsciousness.

### Neurological Effects

MC acts on the central nervous system (CNS) as a CNS depressant. Mild forms of CNS depression have been described in people following exposures as low as 200 ppm for several hours. The measures of CNS depression included subtle changes in visual and auditory functions. These findings were characterized by the authors as decreased vigilance and responsiveness to visual and auditory signals. The MC exposure that produced these effects are roughly equivalent to a blood concentration of approximately

4 mg/L (approximately 1/100 of a lethal amount) and a carboxyhemoglobin (COHb) level of 6%. These effects would be similar to someone consuming 2-3 drinks over a 1-2 hr period. Other studies, measuring different neurological endpoints were negative. Higher concentrations of MC cause lightheadedness, difficulty in maintaining concentration, dizziness, irritation, and unconsciousness as summarized below:

Effect	Concentration ppm	Exposure Concentration	Estimated Blood Concentration	
			MC (mg/L)	COHb (%)
Odor Threshold	100-300	On exposure	--	--
No acute effects	100-200	Up to 7.5 hrs	1-2	3-5
Altered responses on sensory and psychomotor tests	200-800	At least 40 min	2-12	5-10
Lightheadedness	500-1000	1-2 hr	7-20	7-12
Irritation, dizziness	2300	30 min	20	10
Paresthesia	7200	10 min	40	6
Unconsciousness	8000-20,000	30 min - 4 hr	100	--

These effects and the corresponding blood MC and COHb levels will be evaluated in relation to estimated MC exposure in Waco in the section on physiologically based pharmacokinetic models.

#### Absorption and Metabolism of Inhaled MC

Evaluation of pulmonary uptake in humans demonstrates that 70-75% of inhaled MC vapor is absorbed. Absorption is rapid, and once exposure ceases, MC is rapidly cleared with only trace levels being present 6 hrs even after exposure to high concentrations of MC. Excretion of MC occurs in expired air and urine. Following exposure of volunteers to 350 ppm MC for 3-hrs, blood concentrations averaged 5.9 mg/L. This compares to the blood levels of 280-700 mg/L in fatal poisonings from MC exposure.

There are two pathways by which inhaled MC is metabolized inside the body illustrated in the figure below:

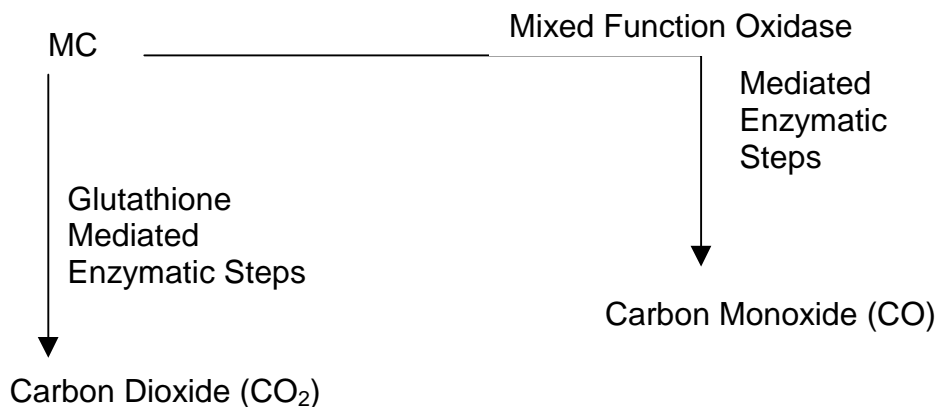

One pathway utilizes an enzyme system called the mixed function oxidases and this pathway produces carbon monoxide (CO). The other pathway involves glutathione transferase enzymes leading to carbon dioxide (CO<sub>2</sub>) production. Although both enzyme systems function in people exposed to MC, the preferred pathway appears to be the mixed function oxidase system. Therefore, people exposed to MC have elevated levels of CO in their bodies.

Inside the body, CO binds to hemoglobin to produce carboxyhemoglobin (COHb). When hemoglobin is bound to CO it cannot bind oxygen leading to potential health concerns arising from diminished blood oxygen levels in the brain and other tissues. In two fatal cases of MC poisoning COHb was elevated to 30% of total hemoglobin. In several non-fatal cases of MC exposure, COHb increased from 1% to 4-15%. COHb is much more persistent in the body than either unbound CO or MC and this property makes COHb a good biomarker for exposures to MC. The half-life of COHb in people is approximately 5 hrs, which means that once formed, one half of the total amount of COHb is degraded after 5 hrs. In addition, some MC is stored in the adipose tissue and slowly released to the blood so COHb is still being formed several hours after MC exposure.

CO exposures can occur in a number of different ways. For example, CO produced from cigarette smokers leads to a significant enhancement of COHb levels. COHb levels in heavy smokers average 4-5%. In addition, CO-exposure occurs in fires and results in oxygen deprivation and asphyxiation. COHb levels in cases of fatal asphyxiation range from 20-70%. COHb levels are elevated in firefighters to levels up to 20%.

It is well known that different individuals have different sensitivities to the adverse effects of chemical exposures and MC is no exception. Sensitivity is often based on a variety of factors including genetic predisposition, gender, age (children or the elderly), diet, and co-exposure to other chemicals. There is good evidence in the scientific

literature that people vary in their ability to metabolize or degrade MC, which would cause some people to be more sensitive than others to MC-mediated toxicities such as central nervous system effects. There is little information available on the possible sensitivity of children to MC exposure. However, children would likely absorb slightly more MC than adults from inhalation exposures because they have a faster breathing rate. It is estimated that the variation in MC metabolism to CO would vary 2-3 fold in the human population. This means that if 100 people were exposed to the same concentration of MC for the same period of time one person might have 10 units of MC in their body whereas another could have 20-30 units.

### Role of Metabolism in Neurotoxicity

There are two possible ways for MC to cause neurological effects such as CNS depression. The first is oxygen deprivation of the brain as a consequence of MC conversion to CO in the body and subsequent binding to hemoglobin. The COHb complex prevents oxygen from binding to hemoglobin, which in turn prevents sufficient amounts of oxygen from reaching critical organs such as the brain. If this mechanism were entirely responsible for the MC-mediated neurotoxicity, then COHb levels should be a good predictor of neurotoxic effects but they are not. Several studies have shown that MC-induced unconsciousness can occur in cases where there is only a small increase in COHb. Moreover, in some cases high concentrations of COHb have been observed in workers exposed to MC or CO without effects on the central nervous system. These findings have led to the scientific consensus that MC must have central nervous system effects, which are independent of COHb concentrations. This second possible mechanism for CNS depression is not well understood and it may or may not require metabolism of MC. Of course, both possible mechanisms may be acting in concert to produce neurological changes.

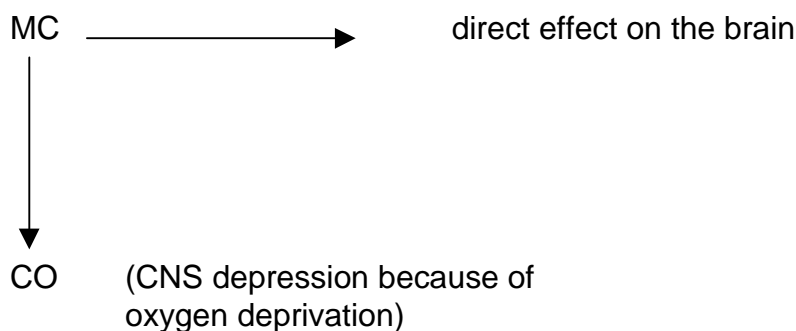

Therefore, prediction of possible neurological changes in the Branch Davidians will require consideration of both peak MC levels in the blood and peak COHb levels during the six-hour period that preceded the fire on April 19, 1993.

## **Physiologically-Based Pharmacokinetic (PBPK) Models for Estimating the Amounts and Fate of Methylene Chloride in the Branch Davidians on April 19, 1993**

It is impossible to know with absolute certainty the exposures that the Branch Davidians encountered on April 19, 1993. However, we do have good information on the number of ferret rounds and canisters emptied into the Compound. We also have reliable information on the times that the ferret rounds were fired or the canisters inserted. According to the information supplied to me by the Office of Special Counsel 386 ferret rounds were fired and 20 canisters inserted as described in the report provided to the Office of Special Counsel by Dr. Jerry Havens. This information was applied to the COMIS computer model to estimate the concentrations of MC in each room of the compound from 6:00 a.m. to 12:20 p.m. The COMIS model estimates the effect of ventilation in each room on the dissipation of MC after ferret rounds were fired or canisters inserted. Thus, highly ventilated rooms would be predicted to retain MC for a shorter period of time than rooms where there is poor ventilation. These models which are reported in the analyses of Dr. Jerry Havens assumed that all ferret rounds entered the building and completely discharged their contents, which is unlikely, and so is a worst case scenario. Based on information supplied to us by the Office of Special Counsel and confirmed by Dr. Jerry Havens it is assumed that each ferret round contained 33.25 g MC and each canister contained 1070 g MC.

These data, supplied to me by Dr. Havens, were applied to PBPK models for predicting the uptake metabolism and retention of MC in blood and the formation and retention of COHb. A short description of the use of PBPK models follows.

### **PBPK Models are Commonly Used in Risk Assessment**

PBPK models use mathematical descriptions of the uptake and disposition of chemical substances to quantitatively describe the movement of a chemical and its breakdown products over time inside the body following different exposure scenarios. PBPK models are also called biologically based tissue dosimetry models. They are being used increasingly in risk assessments designed to set safe exposure levels for a wide variety of chemical substances in the workplace or the general environment. The U.S. Environmental Protection Agency (EPA), The Occupational Safety and Health Administration (OSHA), The Food and Drug Administration (FDA), and the National Toxicology Program (NTP) use PBPK models as an important scientific tool important in meeting their regulatory and public health mandates. These agencies or organizations use PBPK models to predict the concentration of a given chemical that will be delivered to a particular part of the body following various combinations of route, dose level and species. PBPK models are most credible and useful in making health assessments when they are validated for multiple exposure scenarios. In other words, when model predictions are shown to be accurate when compared to real data for some exposure scenarios, they become more useful in predicting chemical disposition following exposure scenarios for which real data are not available. In the case of MC, PBPK

models have been used by OSHA, EPA, the Agency for Toxic Substances Disease Registry (ATSDR) (responsible for making health assessments for people residing in the vicinity of superfund sites) and several states as a key component in setting standards of acceptable exposures for MC.

PBPK Models for MC

We are fortunate to have a scientifically credible model for evaluating MC exposure encountered by the Branch Davidians (Andersen et al., 1991). A schematic representation of the model is found in Andersen's full paper in Appendix C.

This model describes the uptake, metabolism, tissue distribution and excretion of MC and CO in both rats and humans following inhalation exposure. It also models the formation and retention of COHb. Predictions in humans from the model were compared to several data sets in the scientific literature from volunteers exposed to CO or MC. An example of some of the human data used in model development is given below.

Concentrations of MC and COHb in venous blood samples from volunteers exposed to 350-ppm MC vapor for 6 hrs.

Time (hr)	Blood MC (mg/L)	COHb (% of Total Heme)
0	0.016	1.5
3	5.9	5.3
5	5.9	7.6
Exposure stopped at 6 hrs		
7	0.9	9.0
12	0.3	6.5
22	0.08	3.8
30	0.04	1.9

In humans, the model was consistent with all available human data that ranged in exposure concentration for 50 - 1000 ppm and duration of exposures from 2 - 8 hrs. Likewise, in rats the model accurately predicted MC behavior following 4 hr exposures to 200 or 1000 ppm MC as well as a 1/2-hr exposure to 5160 ppm. Therefore, the model appears to be valid for both rats and humans over a wide exposure range for MC. We conclude that the Andersen model is the best scientific tool available to predict the uptake and disposition of MC inside the bodies of the Branch Davidians on April 19, 1993. It is worth noting here that none of the previous evaluations of the potential

health effects of MC at Waco used these models or in any way attempted to evaluate the amount of MC inside the bodies of the Branch Davidians. These previous investigations are therefore, incomplete.

#### Application of PBPK Models for MC Exposures to Adults and Children inside the Branch Davidian Complex

Six exposure scenarios were used for the PBPK models. All of them assumed that the 386 ferret rounds fired on April 19 reached the inside of the Compound. Five of the exposure scenarios vary only in the room locations of the two CS canisters inserted by CEV-1 at 11:49:45 and 11:50:25 a.m. The possible scenarios are listed below:

1. Room 27 - 2 canisters
2. Room 8 - 2 canisters
3. Room 8 - 1 canister; Room 27 - 1 canister
4. Room 30 - 2 canisters
5. Room 27 - 0.5 canisters; Room 30 - 1.5 canisters

Based on an extensive review by Office of Special Counsel staff of eyewitness statements, Davidian statements, mensuration data, FLIR imagery and technical capabilities of the M-S canisters, scenario 5 is considered the most likely scenario. The worst case scenario for MC exposure listed above would be 2 canisters in Room 27 because of the poorer ventilation in that room (bunker). Although we have considered this scenario, we agree with Office of Special Counsel analyses, that such a scenario is virtually impossible.

We assumed that, for all 5 scenarios described above, individuals would have stayed in the same room from 6:00 a.m. until 12:20 p.m. We also applied a 6<sup>th</sup> exposure scenario, which can also be considered worst case;

6. Individuals in Room 19 from 6:00 a.m. to 8:30 a.m. who then moved to the bunker (Room 27).

This scenario was added because individuals in Room 19 would have had significant exposure to MC over the course of the morning of April 19 (see Dr. Haven's room by room predictions of MC air concentrations) and would already have COHb levels higher than in any other room prior to insertion of the canisters at 11:50 a.m. (see Figures 2 and 9 in the appendix).

The PBPK model developed by Andersen (1991) and used in our evaluation of possible MC-mediated neurotoxicity consisted of physiological parameters present in 183-LB adult males. Since children were also inside the Compound and were likely exposed to



MC, we modified the PBPK model to account for physiological parameters common to 50-LB children. Parameters modified for children are as follows:

Parameter	Adult	Child
Body weight (kg)	83	22.7
Alveolar ventilation (L/hr)	394.6472	151.3339
Cardiac output (L/hr)	330.7089	133.5594
Vmax metabolism constant (mg/hr)	137.7954	55.6497
Kf metabolism constant (hr <sup>-1</sup> )	0.5313	0.7835
RENCO (endogenous CO production) (mg/hr)	4.6233	1.8672
DL (diffusing capacity of the lung for CO) (liter/hr/mm Hg)	3.3805	1.0267

All other parameters used by Andersen (1991) were assumed to be the same for adults and children.

Model predictions were made for blood MC levels, blood CO levels and the percentage of blood heme occupied by CO (COHb) for people in every room of the Branch Davidian Complex. Heme is the component of blood, which binds oxygen and carries it to various cells and tissues of the body including the brain. These predictions span all time points between 6:00 a.m. and 12:20 p.m. and are made for both a 50-LB child and a 183-LB adult. As stated earlier, the models are based on the MC concentration estimates provided by Dr. Havens. Our review of Dr. Haven's findings satisfied us that his data are credible and appropriate for our use in applying them to our PBPK models.

Tables 1-10 (Blood MC) and 11-20 (COHb) depict some of the model results for adults and children for each of the six exposure scenarios. These tables are found in Appendix A at the end of the report. For blood MC and COHb concentrations, results are given for the time of peak concentration, the amount of MC or COHb at that peak, and the concentration of MC or COHb at 12:20 p.m.

In general, the models indicate that children would have slightly higher blood MC and COHb levels than adults from exposure to equivalent air concentrations of MC. Figures 1-14 (1-7 children, 8-14 adults) in Appendix B illustrate the time course for air concentrations of MC (from Dr. Haven's analyses), blood MC levels, blood CO

concentrations and COHb concentrations. Figure 1 is shown here as an example to illustrate the kind of information obtained from the models.

Figure 1 MC air concentration, MC blood concentration, CO in blood and %COHb from 6AM to 12:20PM  
Child in room 27; exposure scenario – two canisters in room 27

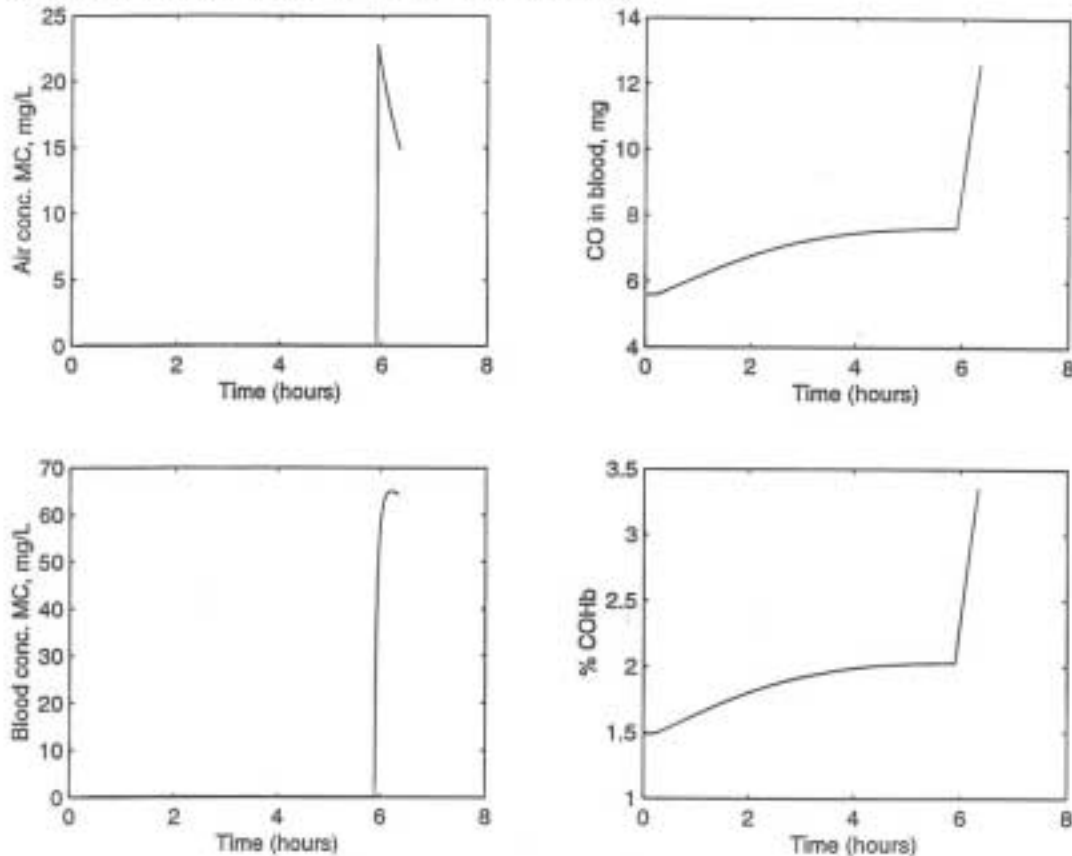

It is evident from these figures that while air MC concentrations rise and fall rapidly as a consequence of exposure to MC released from canisters or ferret rounds, blood MC concentrations are slower to decline. This difference in the rate of decline is because MC is quickly lost from the air by ventilation. However, MC must be either exhaled or degraded for it to be removed from inside the body. Also, MC is stored in fatty tissues to some extent and then slowly released into the blood, so it takes several hours for MC to be removed from the body whereas air concentrations dissipate rapidly in rooms where there is good ventilation.

The highest blood MC concentrations predicted were 65 mg/L in children in Room 27 (2 canisters in Room 27 scenario). Adult concentrations in the same scenario would be 62 mg/L. In general, for each scenario, predicted concentrations in adults are slightly lower than in children. The 2 canister in Room 27 scenario is considered by the Office of Special Counsel to be essentially an impossible scenario due to the depth of penetration by the CEV, location of the bunker, range and width of the spray emitted and other factors. The most likely scenario would be the 1.5 canister in Room 30 and

0.5 canister in Room 27 scenario. In that scenario the predicted blood concentration in Room 27 would be 16 mg/L for children. Below is a list of any predicted blood MC concentrations of greater than 20 mg/L for any of the scenarios evaluated:

Scenario	Room	Blood MC Peak		Time of Peak	Blood MC at 12:20 p.m.
		MG/L Children	Adult		
2 can Room 27	5	52	46	6:07 a.m.	0.1
	7	42	38	9:12 a.m.	0.2
	19	37	33	11:56 a.m.	0.2
	27	65	62	12:12 p.m.	61
2 can Room 8	5	52	46	6:07 a.m.	0.1
	7	41	38	9:12 a.m.	0.2
	8	26	23	11:56 a.m.	1.8
	19	37	33	11:56 a.m.	0.2
1 can Room 8	5	52	46	6.07 a.m.	0.1
1 can Room 27	7	42	38	9:12 a.m.	0.2
	19	37	33	11:56 a.m.	0.2
	27	34	32	12:16 p.m.	32
2 can Room 30	5	52	46	6:07 a.m.	0.1
	7	42	38	9:12 a.m.	0.2
	19	37	33	7:21 a.m.	0.2
1.5 can Room 30	5	52	46	6:07 a.m.	0.1
0.5 can Room 27	7	42	38	9:12 a.m.	0.2
	19	37	33	11:56 a.m.	0.2

It is interesting to note that in the most likely scenario (1.5 can Room 30; 0.5 can Room 27) the highest predicted blood MC concentrations in children in Room 30 were 10 mg/L

and 16 mg/L in Room 27. The expected ventilation rate in Room 30 lessened both the magnitude and duration of MC compared to Room 27.

The Tables (1-20) also provide predictions for COHb based on each of the various exposure scenarios. COHb concentrations in the body are slow to respond to MC exposure because the inhaled MC must be metabolized to CO before the CO binds to hemoglobin and this involves multiple enzymatic steps as described earlier. The predicted time course for COHb as well as MC is illustrated in Figures 1 - 10. Figure 1 (shown earlier) depicts the predictions for 2 canisters in Room 27, which show that while MC concentrations were high from 11:50 a.m. to 12:20 p.m. COHb concentrations would only start increasing around 12:05 p.m. and still were not considered high at 12:20 p.m. Once formed COHb has a 5-hr half-life so the highest COHb levels were predicted in rooms where canisters were inserted earlier in the morning. For example, the highest predicted COHb concentration (5.4) occurred in children who were in Room 19. This peak COHb concentration would have occurred at 8:58 a.m. over an hour after the canister was inserted; the predicted COHb concentration in these same children at 12:20 p.m. was 3.9. If, however, a child moved from Room 19 to Room 27 at 8:30 a.m. and stayed there COHb levels would have been 5.3% at 12:20 p.m. These points are illustrated in Figure 2 from the appendix shown below.

Figure 2 MC air concentration, MC blood concentration, CO in blood and %COHb from 6AM to 12:20PM  
Child moving from Room 19 to Room 27 at 8:30; exposure scenario 2 canisters in room 27

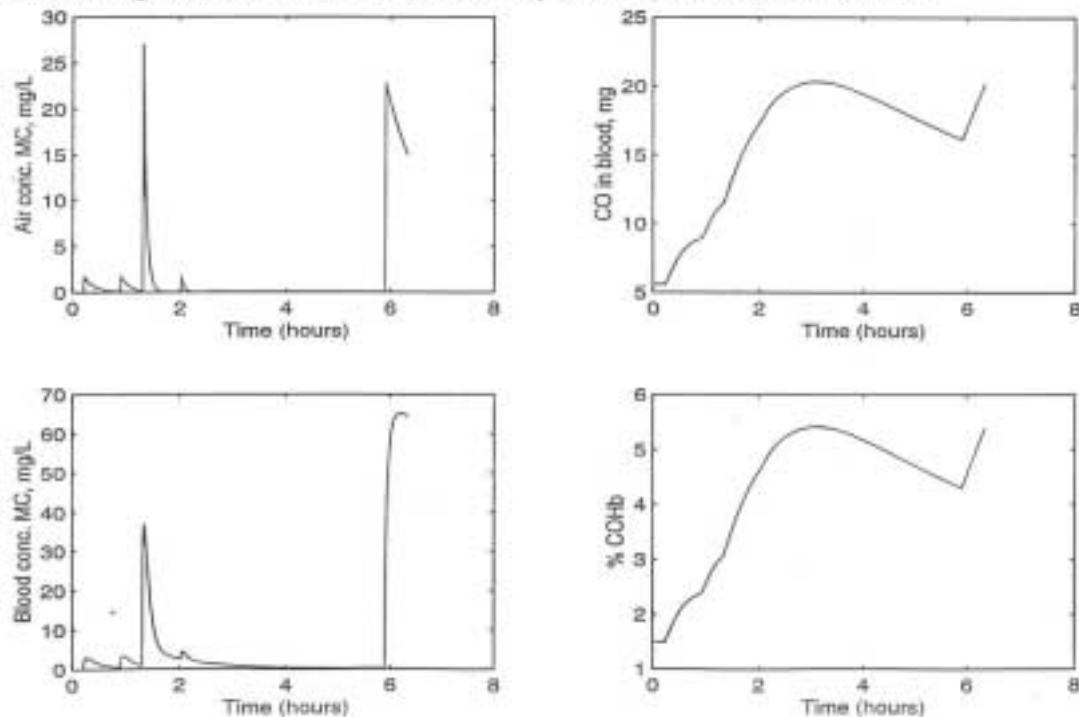

within the general U.S. population COHb levels in heavy smokers range from 4-5% compared to 1.5% for non-smokers.

#### Relevance of predicted MC and COHb concentrations to possible health effects

There were two overarching questions posed by the OFFICE OF SPECIAL COUNSEL regarding MC effects on the Branch Davidians in the Waco Compound:

1. Did the MC exposures inside the Waco Compound kill any of the Branch Davidians on April 19, 1993?
2. Did the MC exposures inside the Compound significantly impair the judgment of the Branch Davidians such that they could not have escaped the fire on April 19, 1993?

My answer to the first question, based on the PBPK models for various exposure scenarios is, no. The highest blood MC predicted was 65 mg/L in children if 2 canisters were inserted in the bunker (Room 27) at approximately 11:50 a.m. This scenario, according to the Office of Special Counsel, is mathematically impossible. The next highest prediction was 52 mg/MC/L MC for children in Room 5 at 6:07 a.m. caused by a canister insertion at 6:05 a.m. None of the scenarios for insertion of 2 canisters around 11:50 a.m. alter this prediction.

Since the lowest blood MC measured in cases of fatal MC poisonings is 281 mg/L following several hours of exposure in an unventilated room, I conclude that MC exposures did not kill any of the Branch Davidians in Waco. This conclusion is strengthened by a number of other points:

1. In cases of fatal MC or CO poisonings, the blood COHb ranged from 20-70%. This compares to the highest prediction of 5.4% in the Waco Compound.
2. The predicted blood COHb and MC concentrations assumed that the Branch Davidians did not leave rooms that received canisters or ferret rounds. If they did leave the rooms, the predicted values would represent overestimates of the exposures experienced by the Branch Davidians.
3. The predicted blood COHb and MC concentrations assumed that exposures were not mitigated by the wearing of gas masks, by putting wet blankets or towels over children or any other technique attempting to limit inhalation by exposure. If exposures were mitigated in these ways the predicted values shown in this document would be overestimates.
4. The predicted MC and COHb blood levels assumed that all 386 ferret rounds and canister insertions found their mark. This is unlikely for the ferret rounds. If some of the ferret rounds did not reach the interior of the Compound, then the

predicted values could be overestimates. In fact, government agents have stated that many ferret rounds did not penetrate the complex.

5. Although rigorous analyses were used to count the number of the 386 ferret rounds fired into the building, there have been claims that as many as 400 were fired. This would represent only a 2.5% increase in MC and since each ferret round contains 33 g MC compared to the 1070 g present in each canister, the effect of an additional 14 ferret rounds would cause a less than 1% increase in the blood MC or COHb levels.
6. Although MC concentrations could have been very high for a short period of time, room ventilation would lead to rapid dissipation of the MC thereby preventing accumulations of lethal levels of MC and its metabolites inside the body.

My answer to the second question, "Did the MC exposures significantly impair the judgment of the Branch Davidians such that they could not have escaped the fire on April 19, 1993," is that some CNS effects likely occurred in some of the Branch Davidians inside the Compound.

The table below helps put the MC exposures of the Branch Davidians in the context of CNS effects reported in the scientific literature.

Effect	Concentration ppm	Exposure Concentration	Estimated Blood Concentration	
			MC (mg/L)	COHb (%)
Odor Threshold	100-300	On exposure	--	--
No acute effects	100-200	Up to 7.5 hrs	1-2	3-5
Altered responses on sensory and psychomotor tests	200-800	At least 40 min	2-12	5-10
Lightheadedness	500-1000	1-2 hr	7-20	7-12
Irritation, dizziness	2300	30 min	20	10
Paresthesia	7200	10 min	40	6
Unconsciousness	8000-20,000	30 min - 4 hr	>100	>20
<b>Waco Worst Case Scenario (2 canisters in the bunker at 11:50 a.m.)</b>			<b>65</b>	<b>5.4</b>
<b>Waco Most Likely Scenario (1.5 canisters Room 30, 0.5 canisters Room 27)</b>			<b>16</b>	<b>3.0</b>

Effects experienced by the Branch Davidians could include subtle alterations in CNS function such as responses to visual and auditory signals, lightheadedness, dizziness and nausea. It is important to note that many of the Branch Davidians would not have experienced those effects based on Office of Special Counsel information on which rooms were occupied during the morning of April 19.

Of greatest concern are the blood MC concentrations rather than the COHb levels since only small effects were observed in studies reported in the scientific literature at blood COHb of less than 5%. The predicted COHb levels at 12:20 p.m. or later were 5% or less in any room. In the bunker (Room 27) predicted COHb levels were 3.4% in children at 12:20 p.m. if 2 canisters (considered an impossible situation) were inserted directly inside the bunker at approximately 11:50 a.m. This number would be higher (5.3% COHb) if, as discussed earlier, a child moved from Room 19 into Room 27 prior to 11:50 a.m. (Figure 2). In contrast to the situation for blood COHb, predicted blood MC levels are clearly in the range of where CNS effects are known to occur. Although predicted concentrations should have not rendered any of the Branch Davidians unconscious, diminished responsiveness and lightheadedness likely occurred in some of the Davidians even if the blood MC predictions are overestimates because of the reasons presented earlier. It is difficult to speculate on the consequences of these effects although reaction times and ability to focus thoughts could have been compromised.

The greatest concern for a possible MC-mediated effect on the Branch Davidians appears to be the impact of MC exposure on their ability to escape the fire. Although such an effect cannot be predicted with any degree of certainty, predicted blood MC concentrations raise this possibility. The greatest concern would be for people in the bunker if any of the canisters were inserted there at approximately 11:50 a.m. The most likely scenario (0.5 canister in the bunker, 1.5 canisters in Room 30) gave predicted blood concentrations of 16 mg/L for children inside the bunker at 12:10 p.m. (Table 9 and Figure 7). Fire experts have concluded that the cafeteria fire started between 12:05 p.m. and 12:06 p.m. so it seems reasonable to assume that if someone wanted to escape the fire, they would do so a few minutes after it started or around 12:10 p.m. The data presented in Figure 7 simulate MC exposures for a child who was in Room 19 (where canisters were inserted early in the morning) then moved to the bunker at 8:30 a.m. Therefore, this Figure presents what could be considered the highest MC exposure from the most likely scenario for canister insertions at 11:50 a.m. This concentration of 16 mg/L would likely cause mild CNS effects such as diminished reactions to visual and auditory stimuli, lightheadedness and other sensations similar to those after a few drinks of an alcoholic beverage. However, it is well known that different people respond differently to alcoholic beverages and to CNS depression so it seems reasonable to assume that some Branch Davidians would be more impaired than others. However, in my opinion, most if not all of the Branch Davidians would have been able to understand the danger of the fire and been able to escape it. Unfortunately, children would be at the greatest risk for not properly understanding the danger of the fire because of their greater sensitivity to a given air concentration of MC and possible controlled information given to the children by adults inside the complex.

The greatest risk for MC influences on escaping the fire would be for the hypothetical case of a person who made an initial decision not to leave or was prevented from leaving then attempted to leave after they had suffered significant smoke inhalation effects.

An additional concern relevant to the issue of whether MC exposures could have diminished the ability of any Branch Davidians or children to escape the Branch Davidian Complex after the fire started is raised by our knowledge that MC is metabolized to CO inside the body. This is because CO is produced by fire and this CO binds to hemoglobin to form COHb that in turn causes oxygen deprivation to the brain. CO mediated oxygen deprivation is the cause of death from smoke inhalation as well as fatal CO poisonings that have occurred in parked cars with the engine running. Since some of the individuals inside the Compound had elevated COHb levels because of MC exposures they could be sensitized to smoke inhalation once the fire started and consequently would become unconscious slightly sooner than they would have if they had not already been exposed to MC. It is important to reemphasize here that this would likely not be a large effect since even in the worst case scenario, elevated COHb levels would be no worse than those occurring in smokers or less than that experienced by firefighters as illustrated below:

- ◆ Normal COHb 1.5%
- ◆ COHb in firefighters 3-15%
- ◆ COHb in smokers 4-6%
- ◆ COHb in worst case scenario in Waco at 12:20 p.m. 5.3%
- ◆ COHb in CO-caused unconsciousness greater than 20%

An additional concern regarding the possibility of neurological effects of the tear gas exposure of the Branch Davidians inside the Compound is based on the possible additive or synergistic effects of exposure to multiple chemicals. These chemicals include MC, CO produced from MC inside the body, CS gas and metabolites of CS. This mixture could be more potent in producing neurological effects than exposure to any of the individual agents present in the ferret rounds or canisters. If this were the case, then the possibility is enhanced that some of the Branch Davidians were unable to escape the Compound after the fire started. Dr. Heinrich's report on CS gas health effects expands on this possibility. Children remain the greatest concern in this regard because they would have higher amounts of MC, CO and CS gas in their bodies than adults as a consequence of exposure to MC and CS gas from the ferret rounds and canisters.



## **MC Concentrations in Remains of the Branch Davidians**

In order to determine if residual MC was present in the remains of the Branch Davidians, samples were analyzed by a sensitive and specific gas chromatographic-mass spectrometry detection system. It would be expected that most, if not all, of the MC present in the Branch Davidians prior to their death would be vaporized by the intense heat of the fire and therefore not present in the remains. Never the less the Office of Special Counsel concluded that MC analyses should be conducted in order to leave no stone unturned in the Waco investigation.

The samples were collected on March 15, 2000, at the Armed forces Institute of Pathology, where they were in the custody of Chief DNA Analyst Demris Lee. They had been stored for some time in a -20°C freezer wrapped in plastic bags containing smaller bags with each of the tissues from one subject and covered with a paper envelope.

The area where samples were taken was determined to be free from possible contaminating sources. Sample identifications were compared and verified with the list of samples to be taken and opened under the hood. Approximately 5 grams of tissue was collected, put into precleaned amber glass bottles, and labeled with the sample identifier. For some samples, only 3 grams of tissue was collected because it was the only tissue from a given subject. In all cases, there was twice as much sample left as was taken. Between samples, cutting tools were cleaned with ethanol provided by Ms. Lee and wiped dry with laboratory wipes. Only NIEHS personnel handled the samples.

Most of these samples were in a very compromised condition. Deterioration and prior handling was evident. Many of the smaller plastic bags had been cut and frozen tissue was simply placed in the cut bag and stored with other tissues from the same subject without being sealed in any way. The tissues looked not only burned, but also dehydrated and in many cases there was less tissue than expected from the manifest. One hundred eleven samples from 60 different individuals were taken.

At the end of the sampling effort, the labels were again verified with the list of samples to be taken and the samples were taped with plastic tape over the edges of the screw caps. The samples were placed, with plastic "bubble wrap" between layers in a styrofoam cooler. To each cooler was added an unopened bottle to serve as a Trip Blank and a bottle opened under the hood, left for approximately the amount of time it would have taken to collect one sample, then closed. This bottle served as a Field Blank. The coolers were packed with "blue ice", sealed with evidence tape, and stored overnight in a locked freezer in a laboratory with access controlled by Ms. Lee.

On March 15, 2000, the coolers were retrieved from the freezers and the evidence tape was found to be intact, indicating that there was no tampering. The coolers were placed in cardboard boxes and sealed again with evidence tape. Chain of Custody documents were signed at that time showing release of the samples to NIEHS personnel by Ms.

Lee. The coolers were then taken by plane to the contract laboratory for analysis. They were not out of sight at any time.

Once at the contract laboratory, the same Chain of Custody documents were checked against the sample labels, signed by NIEHS and laboratory personnel, and the samples were stored in a locked box in a locked freezer, in a controlled-access laboratory for later determinations of methylene chloride. Personnel conducting the chemical analyses were not informed of the origin of the samples.

MC was only detected in one sample obtained from an individual identified as 5B. This was a sample of heart tissue from Douglas Martin whose body was found in the stairwell above the auditorium and he died of smoke inhalation. The MC concentration was low in this sample. This result does not permit us to conclude that people inside the Compound were not exposed to MC because of the condition of the samples and the recognition that the fire would likely vaporize any MC present in people.

### **Experiments in Rats**

Evaluation of the data from the MC exposure and PBPK models raised several issues relative to the effects on CNS function. These issues include the following:

1. What is the nature and magnitude of effects on CNS function following possible MC exposure scenarios encountered inside the compound?
2. Were elevated levels of CO and COHb, and subsequent oxygen deprivation inside the bodies of the Branch Davidians the cause of any CNS effects?
3. Did elevated levels of blood CO and COHb because of MC exposure render any of the Branch Davidians more susceptible to smoke inhalation and less able to escape the fire?
4. Did the direct effects of blood MC on CNS function render any of the Branch Davidians more susceptible to smoke inhalation and less able to escape the fire?
5. What were the CNS effects of combined exposures to MC and CS gas?

Although we will never know with absolute certainty the magnitude of CNS effects occurring inside the compound we can use predictions from the exposure and PBPK models to design experiments in rodents to provide the best possible answers to the five questions listed above. Animal models are frequently relied on to set safe exposure levels in the workplace (OSHA), general environment (EPA), consumer products (Consumer Products Safety Commission), pharmaceuticals and food additives (FDA) and around Superfund sites (ATSDR) for a wide variety of chemicals. However, rodents

are not people and from time to time rodent data will either over or underestimate human risks.

With these issues and thoughts in mind, we conducted some neurobehavioral studies in rats. Our studies are limited in scope because of the time frame required to conduct them, and analyze the data in a scientifically credible way. The only question that we have addressed in our rodent neurobehavioral studies is question three.

"Did elevated levels of blood CO and COHb because of MC exposure render any of the Branch Davidians more susceptible to CO (mimicking smoke inhalation) and less able to escape the fire?"

Although each is important, this questions specifically addresses the issue of the Branch Davidians ability to escape the fire because of elevated CO blood levels consequent from MC exposure. Failure to address the other four questions does not influence my overall conclusions presented in this report as they would serve only to provide more detail on the magnitude of CNS depression likely experienced by the Branch Davidians. The behavioral test used on the rats is called an aversion avoidance test, which will be described in more detail under Experiments 4 and 5.

Five separate experiments were conducted to validate methodologies and conduct neurobehavioral assessments in rodents. These are summarized on the following pages. A National Institutes of Health Animal Care and Use Committee, which reviews the procedures used to insure humane and ethical treatment of animals, approved animal experiments reported on in this report. All experiments were conducted according to guidelines for Good Laboratory Practices designed to minimize cases of improper or invalid experiments.

### Experiment 1

**Objectives:** To verify blood collection method, to determine the stability of rat blood COHb, and to evaluate the variability in COHb levels between unexposed rats.

**Methods:** Blood (1 ml) was collected from unexposed rats (not restrained in nose tubes) by open chest cardiac puncture using blood-gas syringes. Blood samples were placed on ice for 0, 30, 60, or 120 minutes, then delivered to Duke University Medical Center (DUMC) for analysis.

**Results:** Two of the 20 samples clotted. This will be prevented by collecting 0.5 ml samples and mixing more thoroughly. Approximately 15-20 minutes were required to deliver samples from Research Triangle Park to DUMC.

Blood COHb was very stable under the conditions of the experiment. %COHb levels ranged from 1.1 to 1.3 over the 2-hr time period. Within group variation was acceptable. Therefore, we conclude that we can reliably quantify blood COHb levels in subsequent experiments.

<u>Time</u>	<u>%COHb</u>
0	1.2
30	1.3
60	1.1
120	1.1

## Experiment 2

**Objectives:** To determine the optimal CO concentration that rats can breathe for 15 minutes and still respond in the aversion avoidance test. This CO concentration is designed to mimic CO exposure from the fire.

**Methods:** Male rats (10-weeks old) were exposed to 0, 6000, 4000, 2000, or 1000 ppm CO for 15 minutes. Immediately after exposure animals were briefly observed for visible CNS effects and then blood was collected for COHb determinations.

**Results:** CNS Effects: Rats exposed to 6000 ppm were very lethargic, with uncoordinated movements, and had reduced response to pain (foot pinch). Rats may still be able to respond in the aversion avoidance test after exposure to 6000 ppm. In rats exposed to 4000 ppm CNS effects (lethargy and uncoordinated movement) were present although less obvious than observed at 6000 ppm and symptoms appeared to improve within about 5 minutes after exposure. Rats exposed to 4000 ppm would likely still be able to respond in the aversion avoidance test. Exposure to 2000 or 1000 ppm had no visible CNS effects on rats.

### Blood COHb Levels:

%COHb levels were significantly greater than controls in all CO exposure groups. %COHb levels at 6000 ppm were significantly lower than levels at 2000 ppm. %COHb levels at 1000 ppm were significantly lower than levels at 2000 and 4000 ppm.

CO conc. ppm:	<u>control</u>	<u>1000 ppm</u>	<u>2000 ppm</u>	<u>4000 ppm</u>	<u>6000 ppm</u>
%COHb	0.7	24.7	39.7	36.3	30.7

Based on COHb levels and CNS effects, 4000 ppm CO was selected as the high concentration to use in future 15-minute exposures (simulation of fire). 4000 ppm CO was considered to be the optimal CO exposure concentration after which animals could still respond in the aversion avoidance test.

Because young rats will be used in future experiments, a pilot test was conducted to determine if 4000 ppm CO would be too toxic for the younger rats. Five 4-week old rats (about 50 gm) were exposed to 4000 ppm for 15 minutes and then evaluated for CNS effects. Exposure to 4000 ppm appeared to have greater CNS effects (lethargy, uncoordinated movements) on young rats than on older rats. The severity of the effects appeared similar to that observed in 10-week old rats exposed to 6000 ppm. Rats seemed to recover slightly after about 5-10 minutes after exposure.

### Experiment 3

Objective: (1) To determine the CO exposure concentration that results in approximately 5% COHb in rats after exposure for 2 hours (mimics % COHb predicted to occur by PBPK models in worst case scenarios in the Branch Davidian complex; (2) To evaluate the CNS effects of sequential exposure to 50 ppm/2 hr (mimicking COHb levels from MC exposure) + 4000 ppm/15 minutes (mimicking fire).

Methods: Based upon computer simulations (PBPK models), exposure of rats to about 50 ppm CO for 2 hr was predicted to result in about 5% COHb; therefore 50 ppm was the initial exposure concentration. If 50 ppm CO did not produce approximately 5% COHb then additional exposures were to be conducted at 60 or 40 ppm CO. Rats were exposed to 50 ppm CO for up to 2 hours. Blood was collected from 5 rats after exposure for 15, 30, 60 and 120 minutes and analyzed for %COHb.

Results: Exposure to 50 ppm CO resulted in approximately 5% COHb after exposure for 60 minutes. Blood COHb remained at about 5% throughout the remainder of the 2-hour exposure.

An additional exposure to 60 ppm CO was conducted to see if a %5 COHb level could be attained more quickly. However, the %COHb continued to increase throughout the 2-hr exposure to about 6%. The 50 ppm exposure concentration produced the best results.

A pilot study was conducted to ensure that the combination of 50 ppm for 2 hours followed by 4000 ppm for 15 minutes would not render the rats unable to respond in the avoidance aversion test. Five rats were exposed to the combination exposure and observed for adverse effects. The animals were lethargic with uncoordinated movement but did not appear to be more affected than the rats exposed only to 4000 ppm for 15 minutes (Expt 2). The mean %COHb in rats exposed to 50 ppm + 4000 ppm was  $32 \pm 6\%$ .

The results generated in Experiments 1-3 were used to establish the final design for the neurobehavioral assessments. A description of the procedures used to assess avoidance/escape abilities of rats is presented next.

### Avoidance/Escape Learning Procedures for Rats Used in Experiments 4 and 5

The two-way shuttle box procedure utilizes the aversive nature of either a mild shock or a sharp blast of air as a negative reinforcer to evaluate learning and memory functioning. This procedure does not depend upon performance of a food motivated response thus, food or water deprivation is not required. Acquisition of discriminated avoidance response is measured in a shuttle box comprised of two compartments with an access to each chamber allowed through a guillotine doorway. The chambers have a floor of stainless steel grids approximately 11/16" apart for rats and 1/2" for mice to which a 0.4mA electric foot shock is applied via a computer controlled shocker scrambler. Chambers have low level house lighting, a cue light in each chamber and a speaker for delivery of tonal cue. Equipment available at NIEHS was obtained from San Diego Instruments, Inc.

Animals were acclimated to handling prior to testing.

Each session began by placing rat into one compartment, closing the chamber door and opening the guillotine door between the two chambers. The computer-controlled session was started and allowed for automatic activation of stimuli and recording of responses.

Animals were allowed a 240-second habituation to the chambers. During this period, the activity of each animal was monitored by investigator observation. Following this warm-up period, the training trials are initiated automatically by the computer program.

Each trial consisted of the presentation of a paired light and tone conditioned stimulus (CS) in the compartment containing the animal. The animal had 8 seconds from the initiation of the light/tone until delivery of the shock. An avoidance response was recorded if the animal exited the side where the light and tone are being delivered with this 8-second interval. If the animal failed to leave the side having the CS within 8 seconds an electric foot shock (0.4mA) is applied to the grids of the floor. Moving to the safe (non-shock) side was recorded as an escape response. If the animal does not make an appropriate response to remove itself from the shock within the 10 seconds shock delivery period, the shock was terminated and the response recorded as an escape loss. Following avoidance response (latency less than 8 seconds), the light-tone cues and/or shock were terminated and a variable inter-trial interval (ITI) 15 seconds initiated. Responses (crosses between chambers) during the ITI were recorded. Latency to make an avoidance response or escape response was recorded.

All animals were given 60 training trials for a total time of approximately 30 minutes per session. Within 3 days of the initial training session, and 24 hours prior to the experimental exposure, animals received a short (30 trials) session to verify performance and retention of the learned task. Immediately following exposure, animals were placed in the shuttle box apparatus and the session started. Each session included a 240-second habituation period followed by 10 trials. During the habituation period animals were observed for activity level and general behavior. Behavior during the testing trials was monitored and recorded.

### Experiments 4 and 5

Objectives: (1) Experiment 4: To evaluate the effects of sequential CO exposure 50 ppm/2 hours (mimicking CO exposure from MC metabolism) followed by 4000 ppm/15 min. (mimicking CO exposure from fire) on active avoidance performance. (2) Experiment 5: To evaluate the effects of 15 min. of 4000 ppm CO exposure alone on rats' active avoidance performance.

Methods: Ten (10) ten-week old Fisher 344 rats were trained, verified, and tested in the shuttle box procedure per CO group, and for the control group in experiment 4. In experiment 5, 4 control animals were tested. See attached shuttle box protocol.

Results: Relative to air-exposed control rats, those exposed to CO, by either protocol, were lethargic, with uncoordinated movements. All animals had achieved a reliable escape or avoidance response by their verification trial. CO exposed animals largely lost the escape response, or decreased from an avoidance to an escape response. In most cases, CO exposed animals' sessions were terminated after 10 trials because the animals were demonstrating a "shut down" response with complete escape loss. They seemed unable to locomote well, although they were clearly anticipating and reacting to the shock. However, immediately on return to the home cage, all CO exposed animals alerted, increased arousal level, and began moving about the cage. Hind limb strength and extensor reflexes were weaker than air-exposed controls (approximately 15 min. after end of exposure).

### Experiment 4

	Air Controls	50/4000 ppm CO Exposed
Escape latencies (sec)	9.3	10.8
Avoidance latencies (sec)	2.6	5.3
Number of escapes	4.4	3.7
Number of Avoids	5.4	1.3
Number of escape losses	0.2	5.0

## Experiment 5

	Air Controls	Air/4000 ppm CO Exposed
Escape latencies (sec)	8.6	11.9
Avoidance latencies (sec)	3.3	3.3
Number of escapes	1.0	1.5
Number of Avoids	9.0	0.0
Number of escape losses	0.0	8.5

The most important comparison relevant to the ability of the Branch Davidians to escape the fire is the number of escape losses. All animals, not exposed to CO had essentially no escape losses and therefore they exhibited full ability to escape or avoid the electric shock. This ability to escape the electric shock was diminished to 15% of normal when rats were exposed to 4000-ppm CO alone (mimicking fire without preexposure to MC). However, when rats were exposed to 50 ppm for two hours (producing 5% COHb) followed by 4000 ppm CO, escape reactions were diminished to only 50% of normal.

Therefore, results from the rat experiments do not support the possibility that CO produced from MC exposure rendered the Branch Davidians, including children, less able to escape the fire. In fact, pre-exposure to low levels of CO either improved or did not change escape/avoidance reactions in rats when they were exposed to high levels of CO (mimicking CO from fire). However, it is important to remember that MC has direct effects on CNS function independent of its metabolism to CO. This would be the case posed in question 4, which was not addressed in our rodent neurobehavioral studies. Therefore, no firm conclusions can be drawn from the rodent studies.

## **General Conclusions**

This report is based on a rigorous and thorough evaluation of the scientific literature concerning health effects of MC coupled with state-of-the-art simulation modeling to predict the possible effects of MC on the Branch Davidians at the Waco Complex on April 19, 1993. In addition, experiments were conducted in rats to evaluate some effects of MC on the Central Nervous System (CNS).

In my opinion, MC exposures did not kill any of the Branch Davidians. However, it appears likely that some Branch Davidians could have experienced CNS depression because of MC exposures. This could have caused decreased response to visual and auditory stimuli, lightheadedness and irritation. It also appears possible that the CNS depression, coupled with decreased oxygen carrying capacity of red blood cells (because of degradation of MC to carbon monoxide inside the body) could have slightly diminished the ability of the Branch Davidians to escape the fire. In my opinion, Branch Davidians would have been able to escape the fire if they decided to right after the fire started. The greatest



risk for MC influences on escaping the fire would be for the hypothetical case of a person who made an initial decision not to leave or was prevented from leaving then attempted to leave after they had suffered very significant smoke inhalation effects.

## **REFERENCES**

- Andersen ME, Clewell HJ, Gargas ML, et al. Physiologically based pharmacokinetic modeling with dichloromethane, its metabolite, carbon monoxide, and blood carboxyhemoglobin in rats and humans. *Toxicol Appl Pharmacol* 108:14-27 (1991).
- ATSDR. Toxicological profile for methylene chloride. Atlanta, GA: Agency for Toxic Substances and Disease Registry (1998).
- Benzon HT, Claybon L, Brunner EA. Elevated carbon monoxide levels from exposure to methylene chloride [letter]. *JAMA* 239:2341 (1978).
- Cherry N, Venables H, Waldron HA, et al. Some observations on workers exposed to methylene chloride. *Br J Ind Med* 38:351-355 (1981).
- Cherry N, Venables H, Waldron H. The acute behavioral effects of solvent exposure. *J Soc Occup Med* 33:13-18 (1983).
- Clewell HJ, Lee T, Carpenter RL. Sensitivity of physiologically based pharmacokinetic models to variation in model parameters: Methylene chloride. *Risk Anal* 14:521-531 (1994).
- DiVincenzo GD, Kaplan CJ. Uptake, metabolism and elimination of methylene chloride vapor by humans. *Toxicol Appl Pharmacol* 59:130-140 (1981).
- Ernst A, Zibrak JD. Carbon monoxide poisoning. *N Eng J Med* 339:1603-1608 (1998).
- Hall AH, Rumack BH. Methylene chloride exposure in furniture-stripping shops: ventilation and respirator practices. *J Occup Med* 32:33-37 (1990).
- International Agency for Research on Cancer. IARC Monogr Eval Carcinog Risk Chem Hum Suppl 7 (1987).
- Leiken JB, Kaufman D, Lipscomb JW, Burda AM, Hryhorczuk DO. Methylene chloride: report of five cases and two deaths. *Am J Emerg Med* 8:534-537 (1990).
- Mahmud M, Kales SN. Methylene chloride poisoning in a cabinet worker. *Environ Health Perspect* 107:769-772 (1999).
- Manno M, Chirillo R, Danniotti G, Cocheo V, Albrizio F. Carboxyhemoglobin and fatal methylene chloride poisoning [letter]. *Lancet* 2(8657):274 (1989).

Marshall MD, Kales SN, Christiani DC, Goldman RH. Are reference intervals for carboxyhemoglobin appropriate? A survey of Boston area laboratories. *Clin Chem* 41:1434-1438 (1995).

NTP. National Toxicology Program--technical report series no. 306. Toxicology and carcinogenesis studies of dichloromethane (methylene chloride) (CAS No. 75-09-2) in F344/N rats and B6C3F1 mice (inhalation studies). Research Triangle Park, NC: U.S. Department of Health and Human Services, Public Health Service, Centers for Disease Control, National Institutes of Health (1986).

NTP. National Toxicology Program. Eighth annual report on carcinogens: 1998 Summary. Report of the National Institute of Environmental Health Sciences, Research Triangle Park, NC, by Technical Resources, Inc., Rockville, MD (1998).

Occupational Safety and Health Administration, Department of Labor. Occupational Safety and Health Standards: Methylene Chloride. 29CFR § 1910.1052 (1998).

Ratney RS, Wegman, DH, Elkins HB. In vivo conversion of methylene chloride to carbon monoxide. *Arch Environ Health* 28:223-226 (1974).

Savolainen H. Carboxyhemoglobin and fatal methylene chloride poisoning. *Lancet* 2(8665):748-749 (1989).

Shusterman D, Quinlan P, Lowengart R, Cone J. Methylene chloride intoxication in a furniture refinisher. *J Occup Med* 32:451-454 (1990).

Soden KJ. An evaluation of chronic methylene chloride exposure. *J Occup Med* 35:282-286 (1993).

Soden KJ, Marras G, Amsel J. Carboxyhemoglobin levels in methylene chloride-exposed employees. *J Occup Environ Med* 38:367-371 (1996).

Soslow A. Methylene chloride. *Clin Toxicol Rev* 9(11):1-2 (1987).

Stewart RD, Fisher TN, Hosko MJ, Peterson JE, Baretta ED, Dodd HC. Experimental human exposure to methylene chloride. *Arch Environ Health* 25:342-348 (1972).

WHO. Environmental health criteria 164: Methylene chloride, 2<sup>nd</sup> ed. World Health Organization, Geneva, Switzerland (1996).

Winek CL, Collom WD, Esposito F. Accidental methylene chloride fatality. *Forensic Sci Int* 18:165-168 (1974).

Winneke G. Behavioral effects of methylene chloride and carbon monoxide as assessed by sensory and psychomotor performance. In: Xintaras C, Johnson BI, de Groot I, eds. Behavioral toxicology. Washington, DC: U.S. Government Printing Office, 130-144 (1974).

# Appendix A

Results from Methylene Chloride and Carbon Monoxide calculations

Table 1  
 Blood MC (mg/L) in Adults  
 Exposure scenario – 2 canisters in room 30

Room	Time of peak	Blood MC at peak	Blood MC at 12:20
H1	6:10	6.72	0.03
Rm1	6:04	9.39	0.02
Rm2	9:17	0.40	0.04
Rm3	9:56	0.10	0.08
Rm4	9:20	0.28	0.07
Rm5	6:07	46.43	0.12
Rm6	9:09	16.92	0.03
Rm7	9:12	37.85	0.22
H8	6:12	0.89	0.01
Rm8	6:15	0.82	0.01
Rm9	6:39	0.18	0.03
Rm10	6:35	0.18	0.02
Rm11	6:17	0.37	0.02
Rm12	7:22	2.70	0.07
Rm13	11:14	1.29	0.01
Rm14	7:15	2.60	0.06
Rm15	7:13	2.80	0.08
FO	11:55	1.30	0.01
SFO12	6:11	1.07	0.01
Rm16	6:37	0.12	0.03
Rm17	8:19	0.59	0.15
Rm18	12:05	14.33	0.24
Rm19	7:21	33.36	0.14
Rm20	7:35	3.60	0.02
Rm21	12:20	0.00	0.00
Rm22	6:14	0.40	0.00
Rm23	6:16	0.14	0.00
Rm24	6:16	2.18	0.01
Rm26	6:12	2.37	0.06
Rm27	12:20	0.36	0.36
Rm29	11:53	2.88	0.28
Rm30	11:50	12.13	0.21
H31	7:55	2.44	0.01
Rm31	6:23	1.66	0.00
Rm32	7:53	11.67	0.01
Rm33	7:55	11.69	0.01
Rm34	7:55	0.95	0.00
Rm35	11:37	0.76	0.00
Rm36	6:58	2.96	0.02
Rm37	7:56	2.03	0.01
Rm38	7:56	2.02	0.01
Rm39	7:56	2.02	0.01
Rm40	7:56	2.16	0.01
H40	6:12	1.82	0.01
SCA12	6:12	1.81	0.01
H41	6:09	2.36	0.01
Rm41	11:28	2.55	0.03

Rm42	11:25	1.81	0.01
Rm43	11:23	1.58	0.02
Rm44	11:21	1.45	0.02
Rm45	11:19	1.37	0.01
Rm46	11:17	1.31	0.01
Rm47	7:39	0.17	0.09
H48	6:09	6.68	0.01
Rm48	11:05	0.75	0.00
Rm49	11:03	0.74	0.00
Rm50	6:08	8.70	0.00
Rm51	6:51	1.23	0.01
H53	6:09	2.34	0.01
Rm52	6:11	1.29	0.01
STO24	6:09	2.13	0.00
Rm53	6:09	2.17	0.01
Rm54	7:35	0.84	0.01
SST12	6:09	1.20	0.00
Rm55	6:07	3.64	0.01
Rm56	6:08	2.87	0.01
SLN23	7:55	2.38	0.01
Rm57	7:56	1.97	0.01
SLS23	6:09	1.06	0.00
Rm58	6:13	1.06	0.00
Rm59	6:10	1.95	0.00
Rm60	6:10	1.31	0.00

Table 2  
 Blood MC (mg/L) in Adults  
 Exposure scenario – 2 canisters in room 8

Room	Time of peak	Blood MC at peak	Blood MC at 12:20
H1	6:07	5.06	0.02
Rm1	6:04	9.39	0.03
Rm2	6:19	0.25	0.03
Rm3	9:22	0.06	0.04
Rm4	6:24	0.13	0.04
Rm5	6:07	46.47	0.12
Rm6	9:09	16.97	0.04
Rm7	9:12	38.18	0.23
H8	11:55	0.80	0.01
Rm8	11:56	23.30	1.48
Rm9	12:04	0.06	0.03
Rm10	11:59	0.09	0.02
Rm11	11:58	0.10	0.02
Rm12	7:22	2.81	0.08
Rm13	11:14	1.29	0.01
Rm14	7:16	2.69	0.07
Rm15	7:13	2.82	0.08
FO	11:55	1.09	0.01
SFO12	11:55	0.84	0.01
Rm16	7:42	0.06	0.03
Rm17	8:20	0.62	0.20
Rm18	12:05	14.28	0.24
Rm19	7:21	33.13	0.14
Rm20	7:35	3.51	0.01
Rm21	12:20	0.00	0.00
Rm22	6:13	0.40	0.00
Rm23	6:16	0.14	0.00
Rm24	6:16	2.18	0.01
Rm26	6:12	2.42	0.08
Rm27	7:53	0.16	0.14
Rm29	12:11	1.47	1.26
Rm30	12:03	2.04	0.92
H31	7:55	2.52	0.01
Rm31	6:23	1.73	0.00
Rm32	7:53	11.34	0.01
Rm33	7:55	11.46	0.01
Rm34	7:55	0.93	0.00
Rm35	11:37	0.74	0.00
Rm36	6:58	2.66	0.01
Rm37	7:56	2.09	0.01
Rm38	7:56	2.09	0.01
Rm39	7:56	2.08	0.01
Rm40	7:56	2.23	0.01
H40	6:12	1.60	0.01
SCA12	6:12	1.65	0.01
H41	6:09	1.97	0.01
Rm41	11:28	2.21	0.02



Rm42	11:25	1.73	0.01
Rm43	11:23	1.53	0.01
Rm44	11:21	1.42	0.02
Rm45	11:19	1.34	0.01
Rm46	11:17	1.28	0.01
Rm47	7:41	0.10	0.07
H48	6:09	6.55	0.01
Rm48	11:05	0.74	0.00
Rm49	11:03	0.73	0.00
Rm50	6:08	8.65	0.00
Rm51	6:51	1.12	0.00
H53	6:09	1.95	0.01
Rm52	6:11	1.04	0.01
STO24	6:09	1.74	0.00
Rm53	6:09	1.78	0.01
Rm54	7:35	0.84	0.00
SST12	6:09	1.20	0.00
Rm55	6:07	3.64	0.00
Rm56	6:08	2.87	0.00
SLN23	7:55	2.47	0.01
Rm57	7:56	2.03	0.01
SLS23	6:09	1.04	0.00
Rm58	6:13	1.06	0.00
Rm59	6:10	1.90	0.00
Rm60	6:10	1.09	0.00

Table 3  
 Blood MC (mg/L) in Adults  
 Exposure scenario – 1 canister in room 8, 1 in room 27

Room	Time of peak	Blood MC at peak	Blood MC at 12:20
H1	6:07	5.06	0.02
Rm1	6:04	9.39	0.03
Rm2	6:19	0.25	0.03
Rm3	9:22	0.06	0.04
Rm4	6:24	0.13	0.04
Rm5	6:07	46.47	0.12
Rm6	9:09	16.97	0.04
Rm7	9:12	38.18	0.23
H8	11:55	0.80	0.01
Rm8	11:56	11.64	0.62
Rm9	12:04	0.06	0.03
Rm10	11:59	0.09	0.02
Rm11	11:58	0.10	0.02
Rm12	7:22	2.81	0.08
Rm13	11:14	1.29	0.01
Rm14	7:16	2.69	0.07
Rm15	7:13	2.82	0.08
FO	11:55	1.09	0.01
SFO12	11:55	0.84	0.01
Rm16	7:42	0.06	0.03
Rm17	8:20	0.62	0.20
Rm18	12:05	14.28	0.24
Rm19	7:21	33.13	0.14
Rm20	7:35	3.51	0.01
Rm21	12:20	0.00	0.00
Rm22	6:13	0.40	0.00
Rm23	6:16	0.14	0.00
Rm24	6:16	2.18	0.01
Rm26	6:12	2.42	0.08
Rm27	12:16	32.38	32.31
Rm29	12:11	0.77	0.66
Rm30	12:02	1.05	0.48
H31	7:55	2.52	0.01
Rm31	6:23	1.73	0.00
Rm32	7:53	11.34	0.01
Rm33	7:55	11.46	0.01
Rm34	7:55	0.93	0.00
Rm35	11:37	0.74	0.00
Rm36	6:58	2.66	0.01
Rm37	7:56	2.09	0.01
Rm38	7:56	2.09	0.01
Rm39	7:56	2.08	0.01
Rm40	7:56	2.23	0.01
H40	6:12	1.60	0.01
SCA12	6:12	1.65	0.01

H41	6:09	1.97	0.01
Rm41	11:28	2.21	0.02
Rm42	11:25	1.73	0.01
Rm43	11:23	1.53	0.01
Rm44	11:21	1.42	0.02
Rm45	11:19	1.34	0.01
Rm46	11:17	1.28	0.01
Rm47	7:41	0.10	0.07
H48	6:09	6.55	0.01
Rm48	11:05	0.74	0.00
Rm49	11:03	0.73	0.00
Rm50	6:08	8.65	0.00
Rm51	6:51	1.12	0.00
H53	6:09	1.95	0.01
Rm52	6:11	1.04	0.01
STO24	6:09	1.74	0.00
Rm53	6:09	1.78	0.01
Rm54	7:35	0.84	0.00
SST12	6:09	1.20	0.00
Rm55	6:07	3.64	0.00
Rm56	6:08	2.87	0.00
SLN23	7:55	2.47	0.01
Rm57	7:56	2.03	0.01
SLS23	6:09	1.04	0.00
Rm58	6:13	1.06	0.00
Rm59	6:10	1.90	0.00
Rm60	6:10	1.09	0.00

Table 4  
 Blood MC (mg/L) in Adults  
 Exposure scenario – 2 canisters in room 27

Room	Time of peak	Blood MC at peak	Blood MC at 12:20
H1	6:07	5.06	0.02
Rm1	6:04	9.39	0.03
Rm2	6:19	0.25	0.03
Rm3	9:22	0.06	0.04
Rm4	6:24	0.13	0.04
Rm5	6:07	46.47	0.12
Rm6	9:09	16.97	0.04
Rm7	9:12	38.18	0.23
H8	11:55	0.80	0.01
Rm8	11:57	0.17	0.01
Rm9	12:04	0.06	0.03
Rm10	11:59	0.09	0.02
Rm11	11:58	0.10	0.02
Rm12	7:22	2.81	0.08
Rm13	11:14	1.29	0.01
Rm14	7:16	2.69	0.07
Rm15	7:13	2.82	0.08
FO	11:55	1.09	0.01
SFO12	11:55	0.84	0.01
Rm16	7:42	0.06	0.03
Rm17	8:20	0.62	0.20
Rm18	12:05	14.28	0.24
Rm19	7:21	33.13	0.14
Rm20	7:35	3.51	0.01
Rm21	12:20	0.00	0.00
Rm22	6:13	0.40	0.00
Rm23	6:16	0.14	0.00
Rm24	6:16	2.18	0.01
Rm26	6:12	2.42	0.10
Rm27	12:12	61.77	60.59
Rm29	6:27	0.64	0.11
Rm30	6:18	0.86	0.10
H31	7:55	2.52	0.01
Rm31	6:23	1.73	0.00
Rm32	7:53	11.34	0.01
Rm33	7:55	11.46	0.01
Rm34	7:55	0.93	0.00
Rm35	11:37	0.74	0.00
Rm36	6:58	2.66	0.01
Rm37	7:56	2.09	0.01
Rm38	7:56	2.09	0.01
Rm39	7:56	2.08	0.01
Rm40	7:56	2.23	0.01

H40	6:12	1.60	0.01
SCA12	6:12	1.65	0.01
H41	6:09	1.97	0.01
Rm41	11:28	2.21	0.02
Rm42	11:25	1.73	0.01
Rm43	11:23	1.53	0.01
Rm44	11:21	1.42	0.02
Rm45	11:19	1.34	0.01
Rm46	11:17	1.28	0.01
Rm47	7:41	0.10	0.07
H48	6:09	6.55	0.01
Rm48	11:05	0.74	0.00
Rm49	11:03	0.73	0.00
Rm50	6:08	8.65	0.00
Rm51	6:51	1.12	0.00
H53	6:09	1.95	0.01
Rm52	6:11	1.04	0.01
STO24	6:09	1.74	0.00
Rm53	6:09	1.78	0.01
Rm54	7:35	0.84	0.00
SST12	6:09	1.20	0.00
Rm55	6:07	3.64	0.00
Rm56	6:08	2.87	0.00
SLN23	7:55	2.47	0.01
Rm57	7:56	2.03	0.01
SLS23	6:09	1.04	0.00
Rm58	6:13	1.06	0.00
Rm59	6:10	1.90	0.00
Rm60	6:10	1.09	0.00

Table 5  
 Blood MC (mg/L) in Adults  
 Exposure scenario – 1.5 canisters in room 30, 0.5 in room 27

Room	Time of peak	Blood MC at peak	Blood MC at 12:20
H1	6:07	6.00	0.03
Rm1	6:04	9.39	0.02
Rm2	9:17	0.36	0.04
Rm3	9:41	0.09	0.07
Rm4	9:20	0.24	0.06
Rm5	6:07	46.44	0.12
Rm6	9:09	16.94	0.03
Rm7	9:12	37.93	0.22
H8	11:55	0.67	0.01
Rm8	6:15	0.62	0.01
Rm9	6:39	0.14	0.03
Rm10	6:34	0.14	0.02
Rm11	6:18	0.28	0.02
Rm12	7:22	2.73	0.07
Rm13	11:14	1.29	0.01
Rm14	7:15	2.62	0.06
Rm15	7:13	2.81	0.08
FO	11:55	1.25	0.01
SFO12	11:55	0.98	0.01
Rm16	6:37	0.10	0.03
Rm17	8:19	0.60	0.17
Rm18	12:05	14.32	0.24
Rm19	7:21	33.29	0.14
Rm20	7:35	3.58	0.01
Rm21	12:20	0.00	0.00
Rm22	6:14	0.40	0.00
Rm23	6:16	0.14	0.00
Rm24	6:16	2.18	0.01
Rm26	6:12	2.38	0.07
Rm27	12:10	15.07	14.67
Rm29	11:53	2.16	0.23
Rm30	11:50	9.10	0.18
H31	7:55	2.46	0.01
Rm31	6:23	1.67	0.00
Rm32	7:53	11.59	0.01
Rm33	7:55	11.64	0.01
Rm34	7:55	0.94	0.00
Rm35	11:37	0.75	0.00
Rm36	6:58	2.88	0.02
Rm37	7:56	2.05	0.01
Rm38	7:56	2.04	0.01
Rm39	7:56	2.04	0.01

Rm40	7:56	2.18	0.01
H40	6:12	1.76	0.01
SCA12	6:12	1.77	0.01
H41	6:09	2.26	0.01
Rm41	11:28	2.46	0.03
Rm42	11:25	1.79	0.01
Rm43	11:23	1.57	0.02
Rm44	11:21	1.44	0.02
Rm45	11:19	1.36	0.01
Rm46	11:17	1.30	0.01
Rm47	7:40	0.15	0.09
H48	6:09	6.65	0.01
Rm48	11:05	0.74	0.00
Rm49	11:03	0.74	0.00
Rm50	6:08	8.69	0.00
Rm51	6:51	1.20	0.01
H53	6:09	2.24	0.01
Rm52	6:11	1.23	0.01
STO24	6:09	2.03	0.00
Rm53	6:09	2.07	0.01
Rm54	7:35	0.84	0.01
SST12	6:09	1.20	0.00
Rm55	6:07	3.64	0.01
Rm56	6:08	2.87	0.01
SLN23	7:55	2.40	0.01
Rm57	7:56	1.98	0.01
SLS23	6:09	1.05	0.00
Rm58	6:13	1.06	0.00
Rm59	6:10	1.94	0.00
Rm60	6:10	1.25	0.00

Table 6  
 Blood MC (mg/L) in Children  
 Exposure scenario – 2 canisters in room 30

Room	Time of peak	Blood MC at peak	Blood MC at 12:20
H1	6:10	7.11	0.03
Rm1	6:04	10.23	0.02
Rm2	9:17	0.40	0.04
Rm3	9:55	0.10	0.08
Rm4	9:20	0.28	0.07
Rm5	6:07	51.59	0.13
Rm6	9:09	19.23	0.03
Rm7	9:12	41.43	0.17
H8	6:12	0.94	0.01
Rm8	6:15	0.84	0.01
Rm9	6:40	0.18	0.03
Rm10	6:34	0.18	0.02
Rm11	6:16	0.38	0.02
Rm12	7:21	2.94	0.07
Rm13	11:14	1.42	0.01
Rm14	7:15	2.83	0.06
Rm15	7:12	3.04	0.08
FO	11:55	1.50	0.01
SFO12	11:55	1.19	0.01
Rm16	6:36	0.12	0.03
Rm17	7:07	0.59	0.15
Rm18	12:05	16.28	0.28
Rm19	7:21	37.02	0.14
Rm20	7:35	3.89	0.02
Rm21	12:20	0.00	0.00
Rm22	6:13	0.43	0.00
Rm23	6:16	0.14	0.00
Rm24	6:16	2.31	0.01
Rm26	6:12	2.47	0.06
Rm27	12:20	0.36	0.36
Rm29	11:53	3.09	0.32
Rm30	11:50	13.63	0.26
H31	7:55	2.71	0.01
Rm31	6:23	1.85	0.00
Rm32	7:53	13.46	0.01
Rm33	7:55	13.51	0.01
Rm34	7:55	1.09	0.01
Rm35	11:37	0.87	0.00
Rm36	6:58	3.22	0.02
Rm37	6:26	2.26	0.01
Rm38	7:56	2.20	0.01
Rm39	7:56	2.19	0.01
Rm40	7:56	2.35	0.01
H40	6:12	1.93	0.01
SCA12	6:12	1.94	0.01
H41	6:09	2.58	0.01
Rm41	11:28	2.79	0.03
Rm42	11:25	2.04	0.01



Rm43	11:23	1.80	0.02
Rm44	11:21	1.66	0.02
Rm45	11:19	1.56	0.01
Rm46	11:17	1.50	0.01
Rm47	7:39	0.17	0.09
H48	6:09	7.39	0.01
Rm48	11:05	0.84	0.00
Rm49	11:03	0.83	0.00
Rm50	6:08	9.97	0.00
Rm51	6:51	1.34	0.01
H53	6:09	2.56	0.02
Rm52	6:11	1.45	0.01
STO24	6:09	2.32	0.00
Rm53	6:09	2.36	0.01
Rm54	7:35	0.91	0.01
SST12	6:09	1.31	0.00
Rm55	6:07	4.12	0.01
Rm56	6:08	3.13	0.01
SLN23	7:55	2.64	0.01
Rm57	7:56	2.14	0.01
SLS23	6:09	1.15	0.00
Rm58	6:12	1.17	0.00
Rm59	6:10	2.12	0.00
Rm60	6:10	1.41	0.00

Table 7  
 Blood MC (mg/L) in Children  
 Exposure scenario – 2 canisters in room 8

Room	Time of peak	Blood MC at peak	Blood MC at 12:20
H1	6:07	5.46	0.02
Rm1	6:04	10.23	0.03
Rm2	6:19	0.25	0.03
Rm3	9:22	0.06	0.04
Rm4	6:24	0.13	0.04
Rm5	6:07	51.64	0.13
Rm6	9:09	19.27	0.03
Rm7	9:12	41.84	0.17
H8	11:55	0.91	0.01
Rm8	11:56	25.82	1.77
Rm9	12:03	0.06	0.03
Rm10	11:58	0.09	0.02
Rm11	11:57	0.11	0.02
Rm12	7:21	3.05	0.07
Rm13	11:14	1.42	0.01
Rm14	7:15	2.93	0.06
Rm15	7:12	3.06	0.07
FO	11:55	1.27	0.01
SFO12	11:55	0.97	0.01
Rm16	7:41	0.07	0.03
Rm17	8:19	0.62	0.20
Rm18	12:05	16.23	0.28
Rm19	7:21	36.77	0.13
Rm20	7:35	3.80	0.01
Rm21	12:20	0.00	0.00
Rm22	6:13	0.43	0.00
Rm23	6:15	0.14	0.00
Rm24	6:16	2.31	0.01
Rm26	6:12	2.50	0.09
Rm27	7:28	0.17	0.14
Rm29	12:11	1.49	1.28
Rm30	12:02	2.09	0.95
H31	7:55	2.81	0.01
Rm31	6:23	1.92	0.00
Rm32	7:53	13.11	0.01
Rm33	7:55	13.23	0.01
Rm34	7:55	1.06	0.00
Rm35	11:37	0.85	0.00
Rm36	6:58	2.88	0.02
Rm37	7:56	2.27	0.01
Rm38	7:56	2.26	0.01
Rm39	7:56	2.26	0.01
Rm40	7:56	2.42	0.01
H40	6:09	1.72	0.01
SCA12	6:12	1.77	0.01
H41	6:09	2.15	0.01
Rm41	11:27	2.45	0.02
Rm42	11:25	1.95	0.01

Rm43	11:23	1.74	0.02
Rm44	11:21	1.62	0.02
Rm45	11:19	1.53	0.01
Rm46	11:17	1.47	0.01
Rm47	7:40	0.10	0.06
H48	6:09	7.24	0.01
Rm48	11:05	0.83	0.00
Rm49	11:03	0.82	0.00
Rm50	6:08	9.91	0.00
Rm51	6:51	1.22	0.00
H53	6:09	2.12	0.01
Rm52	6:11	1.18	0.01
STO24	6:09	1.89	0.00
Rm53	6:09	1.93	0.01
Rm54	7:35	0.91	0.00
SST12	6:09	1.31	0.00
Rm55	6:07	4.12	0.00
Rm56	6:08	3.12	0.00
SLN23	7:55	2.74	0.01
Rm57	7:56	2.20	0.01
SLS23	6:09	1.13	0.00
Rm58	6:13	1.17	0.00
Rm59	6:10	2.07	0.00
Rm60	6:10	1.18	0.00

Table 8  
 Blood MC (mg/L) in Children  
 Exposure scenario – 1 canister in room 8, 1 in room 27

Room	Time of peak	Blood MC at peak	Blood MC at 12:20
H1	6:07	5.46	0.02
Rm1	6:04	10.23	0.03
Rm2	6:19	0.25	0.03
Rm3	9:22	0.06	0.04
Rm4	6:24	0.13	0.04
Rm5	6:07	51.64	0.13
Rm6	9:09	19.27	0.03
Rm7	9:12	41.84	0.17
H8	11:55	0.91	0.01
Rm8	11:56	12.86	0.77
Rm9	12:03	0.06	0.03
Rm10	11:58	0.09	0.02
Rm11	11:57	0.11	0.02
Rm12	7:21	3.05	0.07
Rm13	11:14	1.42	0.01
Rm14	7:15	2.93	0.06
Rm15	7:12	3.06	0.07
FO	11:55	1.27	0.01
SFO12	11:55	0.97	0.01
Rm16	7:41	0.07	0.03
Rm17	8:19	0.62	0.20
Rm18	12:05	16.23	0.28
Rm19	7:21	36.77	0.13
Rm20	7:35	3.80	0.01
Rm21	12:20	0.00	0.00
Rm22	6:13	0.43	0.00
Rm23	6:15	0.14	0.00
Rm24	6:16	2.31	0.01
Rm26	6:12	2.50	0.09
Rm27	12:20	34.27	34.27
Rm29	12:11	0.77	0.66
Rm30	12:02	1.07	0.50
H31	7:55	2.81	0.01
Rm31	6:23	1.92	0.00
Rm32	7:53	13.11	0.01
Rm33	7:55	13.23	0.01
Rm34	7:55	1.06	0.00
Rm35	11:37	0.85	0.00
Rm36	6:58	2.88	0.02
Rm37	7:56	2.27	0.01
Rm38	7:56	2.26	0.01
Rm39	7:56	2.26	0.01
Rm40	7:56	2.42	0.01
H40	6:09	1.72	0.01
SCA12	6:12	1.77	0.01

H41	6:09	2.15	0.01
Rm41	11:27	2.45	0.02
Rm42	11:25	1.95	0.01
Rm43	11:23	1.74	0.02
Rm44	11:21	1.62	0.02
Rm45	11:19	1.53	0.01
Rm46	11:17	1.47	0.01
Rm47	7:40	0.10	0.06
H48	6:09	7.24	0.01
Rm48	11:05	0.83	0.00
Rm49	11:03	0.82	0.00
Rm50	6:08	9.91	0.00
Rm51	6:51	1.22	0.00
H53	6:09	2.12	0.01
Rm52	6:11	1.18	0.01
STO24	6:09	1.89	0.00
Rm53	6:09	1.93	0.01
Rm54	7:35	0.91	0.00
SST12	6:09	1.31	0.00
Rm55	6:07	4.12	0.00
Rm56	6:08	3.12	0.00
SLN23	7:55	2.74	0.01
Rm57	7:56	2.20	0.01
SLS23	6:09	1.13	0.00
Rm58	6:13	1.17	0.00
Rm59	6:10	2.07	0.00
Rm60	6:10	1.18	0.00

Table 9  
 Blood MC (mg/L) in Children  
 Exposure scenario – 2 canisters in room 27

Room	Time of peak	Blood MC at peak	Blood MC at 12:20
H1	6:07	5.47	0.02
Rm1	6:04	10.23	0.03
Rm2	6:19	0.25	0.03
Rm3	9:22	0.06	0.04
Rm4	6:24	0.13	0.04
Rm5	6:07	51.64	0.13
Rm6	9:09	19.27	0.03
Rm7	9:12	41.84	0.17
H8	11:55	0.91	0.01
Rm8	11:57	0.18	0.01
Rm9	12:03	0.06	0.03
Rm10	11:58	0.09	0.02
Rm11	11:57	0.11	0.02
Rm12	7:21	3.05	0.07
Rm13	11:14	1.42	0.01
Rm14	7:15	2.93	0.06
Rm15	7:12	3.06	0.07
FO	11:55	1.27	0.01
SFO12	11:55	0.97	0.01
Rm16	7:41	0.07	0.03
Rm17	8:19	0.62	0.20
Rm18	12:05	16.23	0.28
Rm19	7:21	36.77	0.13
Rm20	7:35	3.80	0.01
Rm21	12:20	0.00	0.00
Rm22	6:13	0.43	0.00
Rm23	6:15	0.14	0.00
Rm24	6:16	2.31	0.01
Rm26	6:12	2.50	0.10
Rm27	12:12	65.01	64.35
Rm29	6:28	0.65	0.11
Rm30	6:17	0.87	0.10
H31	7:55	2.81	0.01
Rm31	6:23	1.92	0.00
Rm32	7:53	13.11	0.01
Rm33	7:55	13.23	0.01
Rm34	7:55	1.06	0.00
Rm35	11:37	0.85	0.00
Rm36	6:58	2.88	0.02
Rm37	7:56	2.27	0.01
Rm38	7:56	2.26	0.01
Rm39	7:56	2.26	0.01

Rm40	7:56	2.42	0.01
H40	6:09	1.72	0.01
SCA12	6:12	1.77	0.01
H41	6:09	2.15	0.01
Rm41	11:27	2.45	0.02
Rm42	11:25	1.95	0.01
Rm43	11:23	1.74	0.02
Rm44	11:21	1.62	0.02
Rm45	11:19	1.53	0.01
Rm46	11:17	1.47	0.01
Rm47	7:40	0.10	0.06
H48	6:09	7.24	0.01
Rm48	11:05	0.83	0.00
Rm49	11:03	0.82	0.00
Rm50	6:08	9.91	0.00
Rm51	6:51	1.22	0.00
H53	6:09	2.12	0.01
Rm52	6:11	1.18	0.01
STO24	6:09	1.89	0.00
Rm53	6:09	1.93	0.01
Rm54	7:35	0.91	0.00
SST12	6:09	1.31	0.00
Rm55	6:07	4.12	0.00
Rm56	6:08	3.12	0.00
SLN23	7:55	2.74	0.01
Rm57	7:56	2.20	0.01
SLS23	6:09	1.13	0.00
Rm58	6:13	1.17	0.00
Rm59	6:10	2.07	0.00
Rm60	6:10	1.18	0.00

Table 10  
 Blood MC (mg/L) in Children  
 Exposure scenario – 1.5 canisters in room 30, 0.5 in room 27

Room	Time of peak	Blood MC at peak	Blood MC at 12:20
H1	6:07	6.50	0.03
Rm1	6:04	10.23	0.02
Rm2	9:17	0.36	0.04
Rm3	9:48	0.09	0.07
Rm4	9:19	0.23	0.06
Rm5	6:07	51.60	0.13
Rm6	9:09	19.24	0.03
Rm7	9:12	41.53	0.17
H8	11:55	0.76	0.01
Rm8	6:15	0.64	0.01
Rm9	6:39	0.14	0.03
Rm10	6:34	0.14	0.02
Rm11	6:17	0.29	0.02
Rm12	7:21	2.97	0.07
Rm13	11:13	1.42	0.01
Rm14	7:15	2.85	0.06
Rm15	7:12	3.04	0.07
FO	11:55	1.44	0.01
SFO12	11:55	1.13	0.01
Rm16	6:36	0.10	0.03
Rm17	8:19	0.60	0.16
Rm18	12:05	16.25	0.28
Rm19	7:21	36.95	0.14
Rm20	7:35	3.87	0.02
Rm21	12:20	0.00	0.00
Rm22	6:13	0.43	0.00
Rm23	6:15	0.14	0.00
Rm24	6:16	2.31	0.01
Rm26	6:12	2.48	0.07
Rm27	12:10	15.77	15.52
Rm29	11:53	2.31	0.26
Rm30	11:50	10.22	0.21
H31	7:55	2.74	0.01
Rm31	6:23	1.86	0.00
Rm32	7:53	13.38	0.01
Rm33	7:55	13.44	0.01
Rm34	7:55	1.08	0.01
Rm35	11:37	0.87	0.00
Rm36	6:58	3.13	0.02
Rm37	6:26	2.26	0.01



Rm38	7:56	2.21	0.01
Rm39	7:56	2.21	0.01
Rm40	7:56	2.37	0.01
H40	6:12	1.87	0.01
SCA12	6:12	1.90	0.01
H41	6:09	2.47	0.01
Rm41	11:28	2.69	0.03
Rm42	11:25	2.02	0.01
Rm43	11:23	1.78	0.02
Rm44	11:21	1.65	0.02
Rm45	11:19	1.55	0.01
Rm46	11:17	1.49	0.01
Rm47	7:39	0.15	0.09
H48	6:09	7.35	0.01
Rm48	11:05	0.84	0.00
Rm49	11:03	0.83	0.00
Rm50	6:08	9.95	0.00
Rm51	6:51	1.31	0.00
H53	6:09	2.44	0.01
Rm52	6:11	1.38	0.01
STO24	6:09	2.21	0.00
Rm53	6:09	2.25	0.01
Rm54	7:35	0.91	0.01
SST12	6:09	1.31	0.00
Rm55	6:07	4.12	0.01
Rm56	6:08	3.13	0.01
SLN23	7:55	2.67	0.01
Rm57	7:56	2.15	0.01
SLS23	6:09	1.14	0.00
Rm58	6:13	1.17	0.00
Rm59	6:10	2.11	0.00
Rm60	6:10	1.35	0.00

Table 11  
 Blood %COHb in Adults  
 Exposure scenario – 2 canisters in room 30

Room	Time of peak	%COHb at peak	%COHb at 12:20
Rm1	9:21	2.09	1.94
Rm2	10:51	1.93	1.90
Rm3	12:20	1.75	1.75
Rm4	11:51	1.93	1.93
Rm5	9:20	4.16	3.46
Rm6	10:7	2.21	2.10
Rm7	11:42	3.44	3.37
H8	7:44	1.68	1.63
Rm8	7:45	1.67	1.62
Rm9	9:14	1.73	1.68
Rm10	8:42	1.67	1.63
Rm11	8:35	1.69	1.64
Rm12	11:57	2.01	2.00
Rm13	11:51	1.58	1.58
Rm14	11:53	1.96	1.96
Rm15	12:5	2.07	2.06
FO	7:43	1.68	1.63
SFO12	7:41	1.68	1.63
Rm16	9:18	1.67	1.64
Rm17	9:52	2.40	2.32
Rm18	12:20	2.46	2.46
Rm19	9:27	4.45	3.79
Rm20	8:28	1.96	1.82
Rm21	6:0	1.50	1.50
Rm22	8:35	1.55	1.54
Rm23	8:48	1.55	1.54
Rm24	8:35	2.17	1.91
Rm26	12:10	1.93	1.93
Rm27	12:20	1.73	1.73
Rm29	12:20	2.02	2.02
Rm30	12:20	1.96	1.96
H31	8:32	1.75	1.68
Rm31	8:22	1.63	1.58
Rm32	9:10	1.72	1.67
Rm33	9:15	1.72	1.68
Rm34	12:7	1.53	1.53
Rm35	12:12	1.52	1.52
Rm36	8:31	1.93	1.81
Rm37	8:31	1.77	1.69
Rm38	8:35	1.75	1.68
Rm39	8:34	1.75	1.68
Rm40	8:32	1.77	1.69
H40	7:54	1.75	1.67
SCA12	7:57	1.78	1.69
H41	7:54	1.74	1.67
Rm41	12:20	1.66	1.66
Rm42	12:4	1.58	1.58
Rm43	12:19	1.58	1.58

Rm44	12:20	1.58	1.58
Rm45	11:56	1.55	1.55
Rm46	11:56	1.55	1.55
Rm47	12:20	1.92	1.92
H48	7:56	1.76	1.66
Rm48	11:37	1.54	1.54
Rm49	11:37	1.54	1.54
Rm50	7:60	1.71	1.62
Rm51	7:58	1.70	1.63
H53	7:54	1.75	1.69
Rm52	8:21	1.68	1.67
STO24	8:14	1.65	1.60
Rm53	8:18	1.73	1.67
Rm54	8:32	1.65	1.62
SST12	8:31	1.61	1.57
Rm55	8:29	1.68	1.62
Rm56	8:29	1.71	1.63
SLN23	8:35	1.73	1.67
Rm57	8:37	1.76	1.70
SLS23	8:2	1.61	1.56
Rm58	8:11	1.63	1.57
Rm59	8:15	1.62	1.58
Rm60	8:14	1.62	1.59

Table 12  
 Blood %COHb in Adults  
 Exposure scenario – 2 canisters in room 8

Room	Time of peak	%COHb at peak	%COHb at 12:20
Rm1	9:48	2.14	2.03
Rm2	10:8	1.72	1.71
Rm3	12:20	1.64	1.64
Rm4	10:31	1.68	1.67
Rm5	9:20	4.18	3.48
Rm6	10:6	2.25	2.13
Rm7	11:42	3.49	3.42
H8	12:11	1.56	1.56
Rm8	12:20	2.34	2.34
Rm9	12:20	1.56	1.56
Rm10	12:20	1.56	1.56
Rm11	12:20	1.57	1.57
Rm12	11:56	2.04	2.04
Rm13	11:51	1.58	1.58
Rm14	11:52	1.99	1.98
Rm15	11:53	2.07	2.06
FO	12:17	1.54	1.54
SFO12	12:12	1.55	1.55
Rm16	9:29	1.59	1.59
Rm17	9:56	2.43	2.37
Rm18	12:20	2.47	2.47
Rm19	9:27	4.42	3.76
Rm20	8:32	1.86	1.73
Rm21	6:0	1.50	1.50
Rm22	8:35	1.55	1.54
Rm23	8:48	1.55	1.54
Rm24	8:35	2.17	1.91
Rm26	12:15	1.94	1.94
Rm27	12:20	1.95	1.95
Rm29	12:20	2.14	2.14
Rm30	12:20	2.22	2.22
H31	8:38	1.72	1.66
Rm31	8:22	1.63	1.58
Rm32	9:10	1.71	1.66
Rm33	9:15	1.71	1.68
Rm34	12:7	1.53	1.53
Rm35	12:12	1.52	1.52
Rm36	8:35	1.84	1.75
Rm37	8:35	1.75	1.67
Rm38	8:40	1.72	1.66
Rm39	8:38	1.73	1.66
Rm40	8:36	1.74	1.67
H40	7:54	1.68	1.63
SCA12	7:54	1.73	1.66
H41	7:55	1.63	1.61
Rm41	12:17	1.62	1.62

Rm42	12:4	1.58	1.57
Rm43	12:18	1.58	1.58
Rm44	12:20	1.58	1.58
Rm45	11:56	1.55	1.55
Rm46	11:55	1.54	1.54
Rm47	12:20	1.76	1.76
H48	7:56	1.71	1.63
Rm48	11:37	1.54	1.54
Rm49	11:37	1.54	1.54
Rm50	7:59	1.71	1.62
Rm51	8:1	1.64	1.59
H53	8:20	1.65	1.63
Rm52	12:1	1.64	1.63
STO24	8:15	1.63	1.59
Rm53	8:19	1.65	1.62
Rm54	8:31	1.65	1.60
SST12	8:31	1.61	1.57
Rm55	8:28	1.68	1.61
Rm56	8:28	1.70	1.62
SLN23	8:41	1.70	1.65
Rm57	8:43	1.73	1.69
SLS23	8:3	1.61	1.56
Rm58	8:12	1.63	1.57
Rm59	8:15	1.62	1.58
Rm60	8:15	1.61	1.58

Table 13  
 Blood %COHb in Adults  
 Exposure scenario – 1 canisters in room 8, 1 in room 27

Room	Time of peak	%COHb at peak	%COHb at 12:20
Rm1	9:48	2.14	2.03
Rm2	10:8	1.72	1.71
Rm3	12:20	1.64	1.64
Rm4	10:31	1.68	1.67
Rm5	9:20	4.18	3.48
Rm6	10:6	2.25	2.13
Rm7	11:42	3.49	3.42
H8	12:11	1.56	1.56
Rm8	12:20	2.16	2.16
Rm9	12:20	1.56	1.56
Rm10	12:20	1.56	1.56
Rm11	12:20	1.57	1.57
Rm12	11:56	2.04	2.04
Rm13	11:51	1.58	1.58
Rm14	11:52	1.99	1.98
Rm15	11:53	2.07	2.06
FO	12:17	1.54	1.54
SFO12	12:12	1.55	1.55
Rm16	9:29	1.59	1.59
Rm17	9:56	2.43	2.37
Rm18	12:20	2.47	2.47
Rm19	9:27	4.42	3.76
Rm20	8:32	1.86	1.73
Rm21	6:0	1.50	1.50
Rm22	8:35	1.55	1.54
Rm23	8:48	1.55	1.54
Rm24	8:35	2.17	1.91
Rm26	7:58	1.92	1.90
Rm27	12:20	2.82	2.82
Rm29	12:20	2.01	2.01
Rm30	12:20	2.05	2.05
H31	8:38	1.72	1.66
Rm31	8:22	1.63	1.58
Rm32	9:10	1.71	1.66
Rm33	9:15	1.71	1.68
Rm34	12:7	1.53	1.53
Rm35	12:12	1.52	1.52
Rm36	8:35	1.84	1.75
Rm37	8:35	1.75	1.67
Rm38	8:40	1.72	1.66
Rm39	8:38	1.73	1.66
Rm40	8:36	1.74	1.67
H40	7:54	1.68	1.63

SCA12	7:54	1.73	1.66
H41	7:55	1.63	1.61
Rm41	12:17	1.62	1.62
Rm42	12:4	1.58	1.57
Rm43	12:18	1.58	1.58
Rm44	12:20	1.58	1.58
Rm45	11:56	1.55	1.55
Rm46	11:55	1.54	1.54
Rm47	12:20	1.76	1.76
H48	7:56	1.71	1.63
Rm48	11:37	1.54	1.54
Rm49	11:37	1.54	1.54
Rm50	7:59	1.71	1.62
Rm51	8:1	1.64	1.59
H53	8:20	1.65	1.63
Rm52	12:1	1.64	1.63
STO24	8:15	1.63	1.59
Rm53	8:19	1.65	1.62
Rm54	8:31	1.65	1.60
SST12	8:31	1.61	1.57
Rm55	8:28	1.68	1.61
Rm56	8:28	1.70	1.62
SLN23	8:41	1.70	1.65
Rm57	8:43	1.73	1.69
SLS23	8:3	1.61	1.56
Rm58	8:12	1.63	1.57
Rm59	8:15	1.62	1.58
Rm60	8:15	1.61	1.58

Table 14  
 Blood %COHb in Adults  
 Exposure scenario – 2 canisters in room 27

Room	Time of peak	%COHb at peak	%COHb at 12:20
Rm1	9:48	2.14	2.03
Rm2	10:8	1.72	1.71
Rm3	12:20	1.64	1.64
Rm4	10:31	1.68	1.67
Rm5	9:20	4.18	3.48
Rm6	10:6	2.25	2.13
Rm7	11:42	3.49	3.42
H8	12:11	1.56	1.56
Rm8	12:18	1.56	1.56
Rm9	12:20	1.56	1.56
Rm10	12:20	1.56	1.56
Rm11	12:20	1.57	1.57
Rm12	11:56	2.04	2.04
Rm13	11:51	1.58	1.58
Rm14	11:52	1.99	1.98
Rm15	11:53	2.07	2.06
FO	12:17	1.54	1.54
SFO12	12:12	1.55	1.55
Rm16	9:29	1.59	1.59
Rm17	9:56	2.43	2.37
Rm18	12:20	2.47	2.47
Rm19	9:27	4.42	3.76
Rm20	8:32	1.86	1.73
Rm21	6:0	1.50	1.50
Rm22	8:35	1.55	1.54
Rm23	8:48	1.55	1.54
Rm24	8:35	2.17	1.91
Rm26	7:58	1.92	1.86
Rm27	12:20	2.84	2.84
Rm29	8:25	1.95	1.85
Rm30	8:11	1.91	1.83
H31	8:38	1.72	1.66
Rm31	8:22	1.63	1.58
Rm32	9:10	1.71	1.66
Rm33	9:15	1.71	1.68
Rm34	12:7	1.53	1.53
Rm35	12:12	1.52	1.52
Rm36	8:35	1.84	1.75
Rm37	8:35	1.75	1.67
Rm38	8:40	1.72	1.66



Rm39	8:38	1.73	1.66
Rm40	8:36	1.74	1.67
H40	7:54	1.68	1.63
SCA12	7:54	1.73	1.66
H41	7:55	1.63	1.61
Rm41	12:17	1.62	1.62
Rm42	12:4	1.58	1.57
Rm43	12:18	1.58	1.58
Rm44	12:20	1.58	1.58
Rm45	11:56	1.55	1.55
Rm46	11:55	1.54	1.54
Rm47	12:20	1.76	1.76
H48	7:56	1.71	1.63
Rm48	11:37	1.54	1.54
Rm49	11:37	1.54	1.54
Rm50	7:59	1.71	1.62
Rm51	8:1	1.64	1.59
H53	8:20	1.65	1.63
Rm52	12:1	1.64	1.63
STO24	8:15	1.63	1.59
Rm53	8:19	1.65	1.62
Rm54	8:31	1.65	1.60
SST12	8:31	1.61	1.57
Rm55	8:28	1.68	1.61
Rm56	8:28	1.70	1.62
SLN23	8:41	1.70	1.65
Rm57	8:43	1.73	1.69
SLS23	8:3	1.61	1.56
Rm58	8:12	1.63	1.57
Rm59	8:15	1.62	1.58
Rm60	8:15	1.61	1.58

Table 15

Blood %COHb in Adults

Exposure scenario – 1.5 canisters in room 30, 0.5 in room 27

Room	Time of peak	%COHb at peak	%COHb at 12:20
H1	9:25	2.34	2.12
Rm1	9:27	2.10	1.96
Rm2	10:46	1.88	1.85
Rm3	12:20	1.72	1.72
Rm4	11:49	1.87	1.87
Rm5	9:20	4.17	3.46
Rm6	10:7	2.22	2.11
Rm7	11:42	3.45	3.38
H8	7:45	1.65	1.61
Rm8	7:47	1.64	1.61
Rm9	9:14	1.69	1.65
Rm10	8:43	1.64	1.61
Rm11	8:37	1.65	1.62
Rm12	11:57	2.02	2.01
Rm13	11:51	1.58	1.58
Rm14	11:53	1.97	1.96
Rm15	12:3	2.07	2.06
FO	7:42	1.65	1.61
SFO12	7:41	1.65	1.61
Rm16	9:20	1.65	1.63
Rm17	9:54	2.41	2.34
Rm18	12:20	2.47	2.47
Rm19	9:27	4.44	3.78
Rm20	8:29	1.94	1.80
Rm21	6:0	1.50	1.50
Rm22	8:35	1.55	1.54
Rm23	8:48	1.55	1.54
Rm24	8:35	2.17	1.91
Rm26	9:22	1.92	1.91
Rm27	12:20	2.56	2.56
Rm29	12:20	1.99	1.99
Rm30	12:20	1.95	1.95
H31	8:33	1.74	1.67
Rm31	8:22	1.63	1.58
Rm32	9:10	1.72	1.66
Rm33	9:15	1.72	1.68
Rm34	12:7	1.53	1.53
Rm35	12:12	1.52	1.52
Rm36	8:32	1.91	1.79
Rm37	8:32	1.76	1.69
Rm38	8:36	1.74	1.67
Rm39	8:35	1.74	1.68
Rm40	8:33	1.76	1.69
H40	7:54	1.73	1.66
SCA12	7:56	1.76	1.68
H41	7:54	1.71	1.65
Rm41	12:20	1.65	1.65
Rm42	12:5	1.58	1.58

Rm43	12:18	1.58	1.58
Rm44	12:20	1.58	1.58
Rm45	11:57	1.55	1.55
Rm46	11:55	1.55	1.54
Rm47	12:20	1.88	1.88
H48	7:56	1.75	1.65
Rm48	11:37	1.54	1.54
Rm49	11:37	1.54	1.54
Rm50	7:59	1.71	1.62
Rm51	7:58	1.68	1.62
H53	8:19	1.73	1.67
Rm52	8:21	1.67	1.66
STO24	8:14	1.64	1.60
Rm53	8:18	1.71	1.65
Rm54	8:31	1.65	1.61
SST12	8:31	1.61	1.57
Rm55	8:29	1.68	1.62
Rm56	8:28	1.70	1.63
SLN23	8:36	1.72	1.66
Rm57	8:38	1.75	1.70
SLS23	8:2	1.61	1.56
Rm58	8:12	1.63	1.57
Rm59	8:15	1.62	1.58
Rm60	8:15	1.62	1.59

Table 16  
 Blood %COHb in Children  
 Exposure scenario – 2 canisters in room 30

Room	Time of peak	%COHb at peak	%COHb at 12:20
Rm1	9:20	2.23	1.96
Rm2	10:36	2.06	1.97
Rm3	12:20	1.81	1.81
Rm4	11:15	2.05	2.02
Rm5	8:13	4.81	3.53
Rm6	9:53	2.45	2.18
Rm7	10:47	3.95	3.74
H8	7:40	1.76	1.64
Rm8	7:40	1.73	1.63
Rm9	8:52	1.81	1.70
Rm10	8:23	1.73	1.64
Rm11	8:18	1.75	1.65
Rm12	11:54	2.14	2.13
Rm13	11:45	1.59	1.59
Rm14	11:50	2.09	2.07
Rm15	12:1	2.22	2.20
FO	7:20	1.75	1.64
SFO12	7:20	1.75	1.63
Rm16	8:60	1.72	1.65
Rm17	9:31	2.69	2.46
Rm18	8:36	2.72	2.64
Rm19	8:58	5.41	3.93
Rm20	8:23	2.13	1.84
Rm21	6:0	1.50	1.49
Rm22	8:30	1.56	1.53
Rm23	8:42	1.56	1.53
Rm24	8:5	2.42	1.92
Rm26	7:27	2.05	2.00
Rm27	12:20	1.80	1.80
Rm29	12:20	2.21	2.21
Rm30	12:20	2.11	2.11
H31	8:24	1.84	1.69
Rm31	7:25	1.67	1.58
Rm32	8:52	1.80	1.68
Rm33	8:56	1.80	1.70
Rm34	12:4	1.53	1.53
Rm35	12:5	1.52	1.52
Rm36	8:24	2.09	1.83
Rm37	8:24	1.87	1.70
Rm38	8:25	1.84	1.69
Rm39	8:25	1.84	1.69
Rm40	8:24	1.87	1.70
H40	7:41	1.84	1.68
SCA12	7:54	1.88	1.70
H41	7:41	1.83	1.68
Rm41	12:13	1.70	1.70
Rm42	11:59	1.60	1.60
Rm43	12:11	1.60	1.60

Rm44	12:16	1.61	1.61
Rm45	11:51	1.56	1.56
Rm46	11:49	1.55	1.55
Rm47	11:41	2.00	2.00
H48	7:16	1.86	1.66
Rm48	11:33	1.54	1.54
Rm49	11:32	1.54	1.54
Rm50	7:56	1.78	1.61
Rm51	7:52	1.77	1.63
H53	7:41	1.85	1.70
Rm52	8:18	1.74	1.69
STO24	7:39	1.70	1.60
Rm53	7:41	1.81	1.68
Rm54	8:27	1.70	1.62
SST12	7:9	1.65	1.57
Rm55	8:26	1.74	1.62
Rm56	8:3	1.77	1.64
SLN23	8:25	1.82	1.68
Rm57	8:26	1.86	1.72
SLS23	7:58	1.64	1.56
Rm58	7:59	1.67	1.57
Rm59	7:39	1.66	1.58
Rm60	7:38	1.67	1.59

Table 17  
 Blood %COHb in Children  
 Exposure scenario – 2 canisters in room 8

Room	Time of peak	%COHb at peak	%COHb at 12:20
Rm1	9:43	2.30	2.08
Rm2	9:60	1.79	1.74
Rm3	12:20	1.67	1.67
Rm4	10:17	1.72	1.70
Rm5	8:14	4.83	3.55
Rm6	9:51	2.50	2.21
Rm7	10:47	4.02	3.80
H8	12:10	1.57	1.57
Rm8	12:20	2.69	2.69
Rm9	12:20	1.57	1.57
Rm10	12:20	1.57	1.57
Rm11	12:20	1.57	1.57
Rm12	11:53	2.19	2.17
Rm13	11:45	1.59	1.59
Rm14	11:49	2.12	2.10
Rm15	11:49	2.22	2.19
FO	12:15	1.55	1.55
SFO12	12:10	1.55	1.55
Rm16	9:14	1.62	1.59
Rm17	9:34	2.74	2.52
Rm18	8:35	2.73	2.64
Rm19	8:58	5.37	3.90
Rm20	8:24	2.00	1.74
Rm21	6:0	1.50	1.49
Rm22	8:30	1.56	1.53
Rm23	8:43	1.56	1.53
Rm24	8:5	2.42	1.92
Rm26	7:29	2.08	2.03
Rm27	12:20	2.05	2.05
Rm29	12:20	2.32	2.32
Rm30	12:20	2.44	2.44
H31	8:27	1.80	1.67
Rm31	7:25	1.67	1.58
Rm32	8:52	1.79	1.67
Rm33	8:56	1.79	1.69
Rm34	12:3	1.53	1.53
Rm35	12:5	1.52	1.52
Rm36	8:25	1.97	1.77
Rm37	8:25	1.84	1.69
Rm38	8:27	1.80	1.67
Rm39	8:27	1.81	1.67
Rm40	8:26	1.84	1.68
H40	7:42	1.75	1.64
SCA12	7:41	1.82	1.67
H41	7:42	1.68	1.61
Rm41	12:10	1.65	1.65
Rm42	11:58	1.59	1.59

Rm43	12:10	1.59	1.59
Rm44	12:15	1.60	1.60
Rm45	11:50	1.56	1.55
Rm46	11:48	1.55	1.55
Rm47	12:20	1.81	1.81
H48	7:14	1.78	1.63
Rm48	11:33	1.54	1.54
Rm49	11:32	1.54	1.54
Rm50	7:56	1.78	1.61
Rm51	7:53	1.69	1.60
H53	7:42	1.70	1.64
Rm52	8:18	1.67	1.65
STO24	7:39	1.67	1.59
Rm53	7:41	1.70	1.63
Rm54	8:27	1.70	1.61
SST12	7:9	1.65	1.57
Rm55	8:26	1.74	1.61
Rm56	8:3	1.77	1.62
SLN23	8:28	1.77	1.66
Rm57	8:30	1.82	1.70
SLS23	7:58	1.64	1.55
Rm58	7:59	1.67	1.57
Rm59	7:39	1.66	1.58
Rm60	7:38	1.65	1.58

Table 18  
 Blood %COHb in Children  
 Exposure scenario – 1 canisters in room 8, 1 in room 27

Room	Time of peak	%COHb at peak	%COHb at 12:20
Rm1	9:43	2.30	2.08
Rm2	9:60	1.79	1.74
Rm3	12:20	1.67	1.67
Rm4	10:17	1.72	1.70
Rm5	8:14	4.83	3.55
Rm6	9:51	2.50	2.21
Rm7	10:47	4.02	3.80
H8	12:10	1.57	1.57
Rm8	12:20	2.42	2.42
Rm9	12:20	1.57	1.57
Rm10	12:20	1.57	1.57
Rm11	12:20	1.57	1.57
Rm12	11:53	2.19	2.17
Rm13	11:45	1.59	1.59
Rm14	11:49	2.12	2.10
Rm15	11:49	2.22	2.19
FO	12:15	1.55	1.55
SFO12	12:10	1.55	1.55
Rm16	9:14	1.62	1.59
Rm17	9:34	2.74	2.52
Rm18	8:35	2.73	2.64
Rm19	8:58	5.37	3.90
Rm20	8:24	2.00	1.74
Rm21	6:0	1.50	1.49
Rm22	8:30	1.56	1.53
Rm23	8:43	1.56	1.53
Rm24	8:5	2.42	1.92
Rm26	7:29	2.08	1.96
Rm27	12:20	3.33	3.33
Rm29	12:20	2.12	2.12
Rm30	12:20	2.19	2.19
H31	8:27	1.80	1.67
Rm31	7:25	1.67	1.58
Rm32	8:52	1.79	1.67
Rm33	8:56	1.79	1.69
Rm34	12:3	1.53	1.53
Rm35	12:5	1.52	1.52
Rm36	8:25	1.97	1.77
Rm37	8:25	1.84	1.69
Rm38	8:27	1.80	1.67
Rm39	8:27	1.81	1.67
Rm40	8:26	1.84	1.68
H40	7:42	1.75	1.64
SCA12	7:41	1.82	1.67
H41	7:42	1.68	1.61



Rm41	12:10	1.65	1.65
Rm42	11:58	1.59	1.59
Rm43	12:10	1.59	1.59
Rm44	12:15	1.60	1.60
Rm45	11:50	1.56	1.55
Rm46	11:48	1.55	1.55
Rm47	12:20	1.81	1.81
H48	7:14	1.78	1.63
Rm48	11:33	1.54	1.54
Rm49	11:32	1.54	1.54
Rm50	7:56	1.78	1.61
Rm51	7:53	1.69	1.60
H53	7:42	1.70	1.64
Rm52	8:18	1.67	1.65
STO24	7:39	1.67	1.59
Rm53	7:41	1.70	1.63
Rm54	8:27	1.70	1.61
SST12	7:9	1.65	1.57
Rm55	8:26	1.74	1.61
Rm56	8:3	1.77	1.62
SLN23	8:28	1.77	1.66
Rm57	8:30	1.82	1.70
SLS23	7:58	1.64	1.55
Rm58	7:59	1.67	1.57
Rm59	7:39	1.66	1.58
Rm60	7:38	1.65	1.58

Table 19  
 Blood %COHb in Children  
 Exposure scenario – 2 canisters in room 27

Room	Time of peak	%COHb at peak	%COHb at 12:20
Rm1	9:43	2.30	2.08
Rm2	9:60	1.79	1.74
Rm3	12:20	1.67	1.67
Rm4	10:17	1.72	1.70
Rm5	8:14	4.83	3.55
Rm6	9:51	2.50	2.21
Rm7	10:47	4.02	3.80
H8	12:10	1.57	1.57
Rm8	12:16	1.57	1.57
Rm9	12:20	1.57	1.57
Rm10	12:20	1.57	1.57
Rm11	12:20	1.57	1.57
Rm12	11:53	2.19	2.17
Rm13	11:45	1.59	1.59
Rm14	11:49	2.12	2.10
Rm15	11:49	2.22	2.19
FO	12:15	1.55	1.55
SFO12	12:10	1.55	1.55
Rm16	9:14	1.62	1.59
Rm17	9:34	2.74	2.52
Rm18	8:35	2.73	2.64
Rm19	8:58	5.37	3.90
Rm20	8:24	2.00	1.74
Rm21	6:0	1.50	1.49
Rm22	8:30	1.56	1.53
Rm23	8:43	1.56	1.53
Rm24	8:5	2.42	1.92
Rm26	7:29	2.08	1.91
Rm27	12:20	3.36	3.36
Rm29	8:3	2.12	1.89
Rm30	7:56	2.07	1.87
H31	8:27	1.80	1.67
Rm31	7:25	1.67	1.58
Rm32	8:52	1.79	1.67
Rm33	8:56	1.79	1.69
Rm34	12:3	1.53	1.53
Rm35	12:5	1.52	1.52
Rm36	8:25	1.97	1.77
Rm37	8:25	1.84	1.69
Rm38	8:27	1.80	1.67
Rm39	8:27	1.81	1.67
Rm40	8:26	1.84	1.68
H40	7:42	1.75	1.64

SCA12	7:41	1.82	1.67
H41	7:42	1.68	1.61
Rm41	12:10	1.65	1.65
Rm42	11:58	1.59	1.59
Rm43	12:10	1.59	1.59
Rm44	12:15	1.60	1.60
Rm45	11:50	1.56	1.55
Rm46	11:48	1.55	1.55
Rm47	12:20	1.81	1.81
H48	7:14	1.78	1.63
Rm48	11:33	1.54	1.54
Rm49	11:32	1.54	1.54
Rm50	7:56	1.78	1.61
Rm51	7:53	1.69	1.60
H53	7:42	1.70	1.64
Rm52	8:18	1.67	1.65
STO24	7:39	1.67	1.59
Rm53	7:41	1.70	1.63
Rm54	8:27	1.70	1.61
SST12	7:9	1.65	1.57
Rm55	8:26	1.74	1.61
Rm56	8:3	1.77	1.62
SLN23	8:28	1.77	1.66
Rm57	8:30	1.82	1.70
SLS23	7:58	1.64	1.55
Rm58	7:59	1.67	1.57
Rm59	7:39	1.66	1.58
Rm60	7:38	1.65	1.58

Table 20

## Blood %COHb in Children

Exposure scenario – 1.5 canisters in room 30, 0.5 in room 27

Room	Time of peak	%COHb at peak	%COHb at 12:20
H1	9:23	2.55	2.16
Rm1	9:27	2.25	1.99
Rm2	10:32	1.99	1.91
Rm3	12:20	1.77	1.77
Rm4	11:11	1.96	1.94
Rm5	8:14	4.81	3.54
Rm6	9:52	2.46	2.19
Rm7	10:47	3.97	3.75
H8	7:40	1.70	1.62
Rm8	7:41	1.68	1.61
Rm9	8:53	1.74	1.66
Rm10	8:27	1.68	1.62
Rm11	8:23	1.70	1.63
Rm12	11:53	2.15	2.14
Rm13	11:47	1.59	1.59
Rm14	11:50	2.09	2.07
Rm15	11:50	2.22	2.20
FO	7:39	1.69	1.61
SFO12	7:22	1.70	1.61
Rm16	9:4	1.69	1.64
Rm17	9:32	2.70	2.47
Rm18	8:36	2.72	2.64
Rm19	8:58	5.39	3.92
Rm20	8:24	2.09	1.81
Rm21	12:20	1.49	1.49
Rm22	8:31	1.55	1.53
Rm23	8:44	1.55	1.53
Rm24	8:6	2.42	1.92
Rm26	7:27	2.05	1.98
Rm27	12:20	3.01	3.01
Rm29	12:20	2.15	2.15
Rm30	12:20	2.08	2.08
H31	8:25	1.83	1.68
Rm31	7:27	1.67	1.57
Rm32	8:52	1.79	1.67
Rm33	8:57	1.79	1.70
Rm34	12:6	1.53	1.53
Rm35	12:9	1.52	1.52
Rm36	8:24	2.06	1.81
Rm37	8:25	1.86	1.70
Rm38	8:26	1.82	1.68
Rm39	8:26	1.83	1.68
Rm40	8:25	1.86	1.70
H40	7:41	1.81	1.67
SCA12	7:54	1.86	1.69
H41	7:41	1.78	1.66
Rm41	12:13	1.69	1.69
Rm42	11:60	1.59	1.59

Rm43	12:12	1.60	1.60
Rm44	12:16	1.60	1.60
Rm45	11:52	1.55	1.55
Rm46	11:51	1.55	1.55
Rm47	12:20	1.95	1.95
H48	7:16	1.84	1.65
Rm48	11:35	1.54	1.54
Rm49	11:34	1.54	1.53
Rm50	7:56	1.77	1.61
Rm51	7:53	1.74	1.62
H53	7:41	1.80	1.69
Rm52	8:18	1.72	1.67
STO24	7:39	1.69	1.59
Rm53	7:41	1.78	1.66
Rm54	8:27	1.69	1.62
SST12	7:10	1.64	1.56
Rm55	8:26	1.74	1.62
Rm56	8:3	1.76	1.63
SLN23	8:26	1.80	1.67
Rm57	8:27	1.84	1.72
SLS23	7:58	1.64	1.55
Rm58	8:1	1.67	1.57
Rm59	7:39	1.66	1.58
Rm60	7:38	1.66	1.58

# Appendix B

Figures: Methylene Chloride and Carbon Monoxide model results

Figure 1 MC air concentration, MC blood concentration, CO in blood and %COHb from 6AM to 12:20PM Child in room 27; exposure scenario – two canisters in room 27

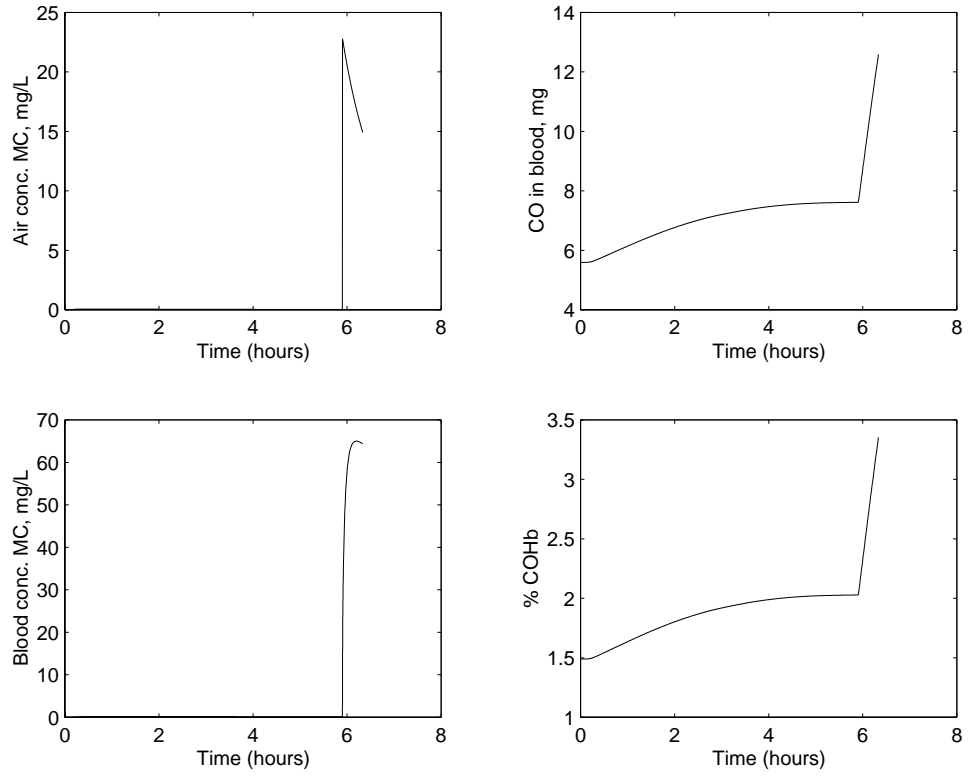

Figure 2 MC air concentration, MC blood concentration, CO in blood and %COHb from 6AM to 12:20PM  
Child moving from Room 19 to Room 27 at 8:30; exposure scenario 2 canisters in room 27

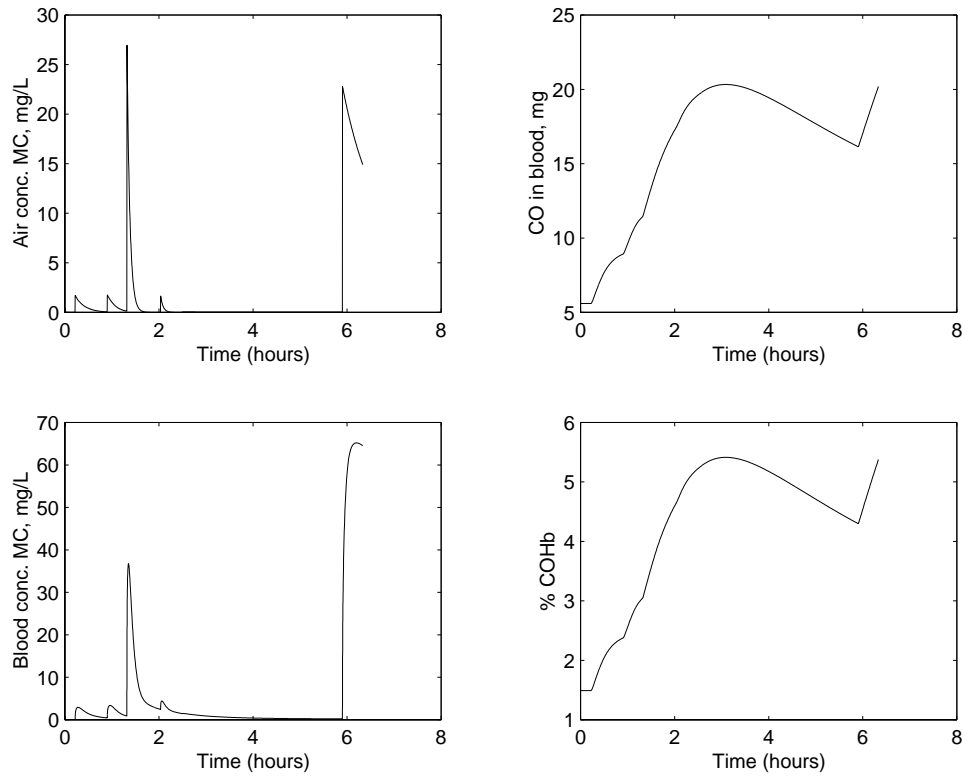



Figure 3 MC air concentration, MC blood concentration, CO in blood and %COHb from 6AM to 12:20PM  
Child in room 8; exposure scenario two canisters in room 8

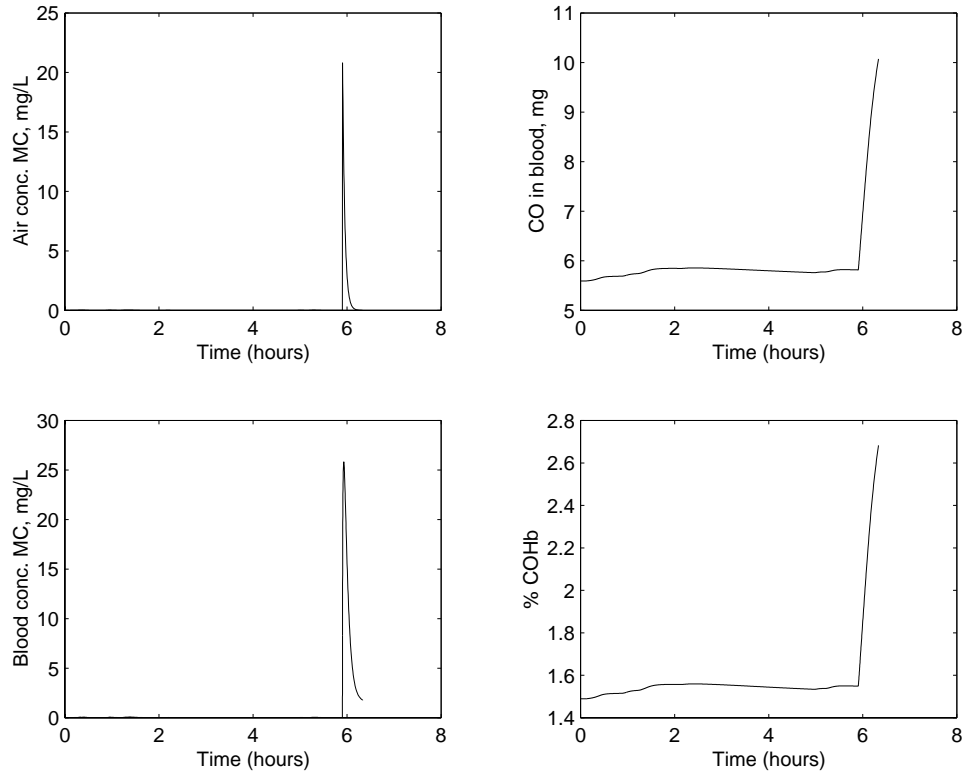

Figure 4 MC air concentration, MC blood concentration, CO in blood and %COHb from 6AM to 12:20PM Child in room 8; exposure scenario is one canister in room 8 and one in room 27

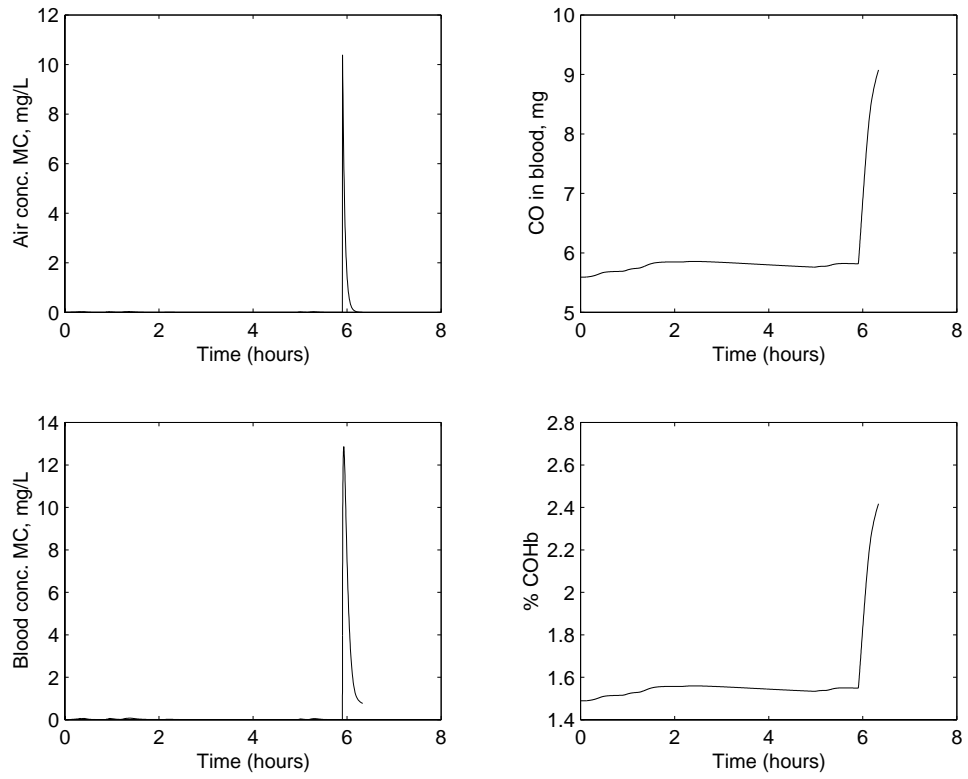

Figure 5 MC air concentration, MC blood concentration, CO in blood and %COHb from 6AM to 12:20PM Child in room 27; exposure scenario one canister in room 8, one in room 27

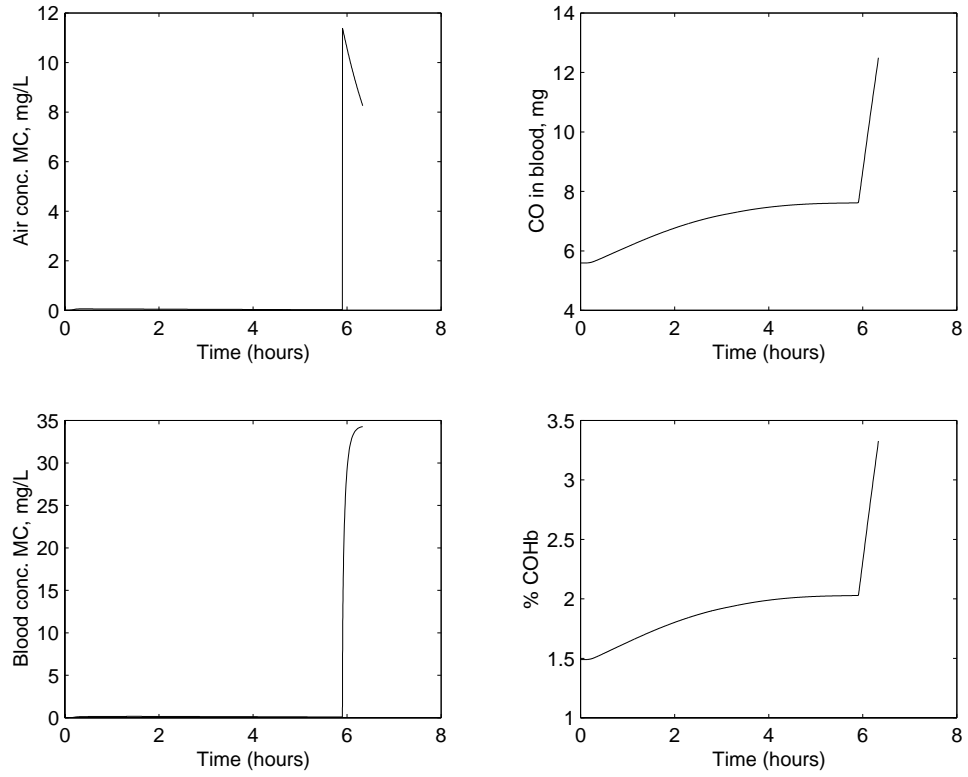

Figure 6 MC air concentration, MC blood concentration, CO in blood and %COHb from 6AM to 12:20PM  
Child in room 30; exposure scenario two canisters in room 30

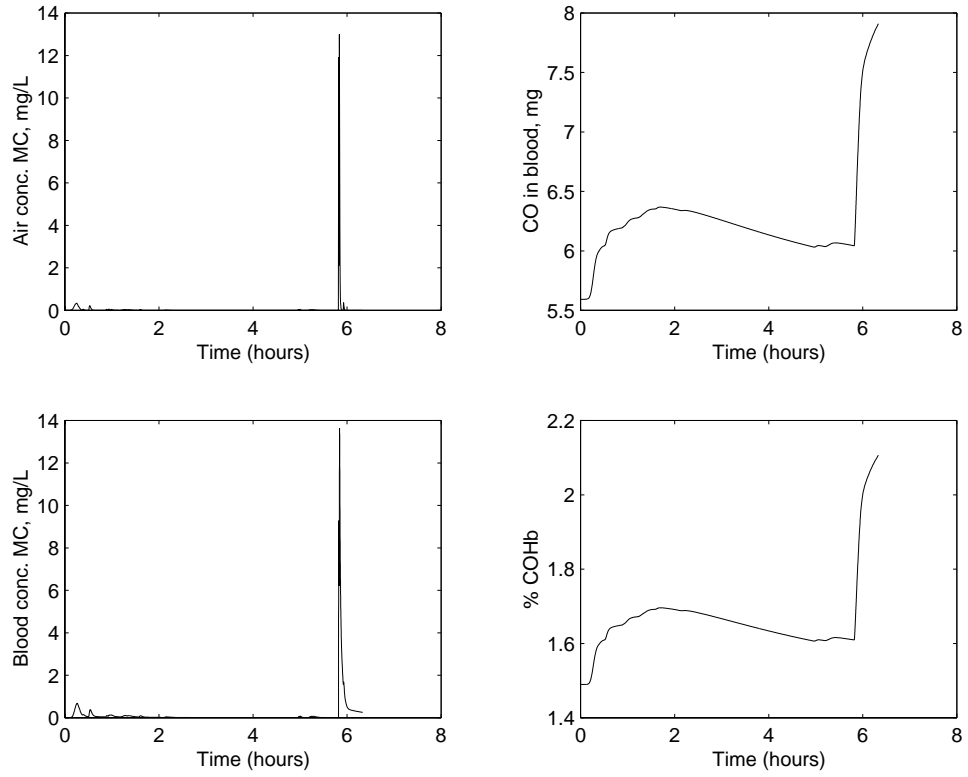

Figure 7 MC air concentration, MC blood concentration, CO in blood and %COHb from 6AM to 12:20PM  
Child moving from Room 19 to Room 27 at 8:30; exposure scenario 1.5 canisters in room 30 and 0.5 in  
room 27

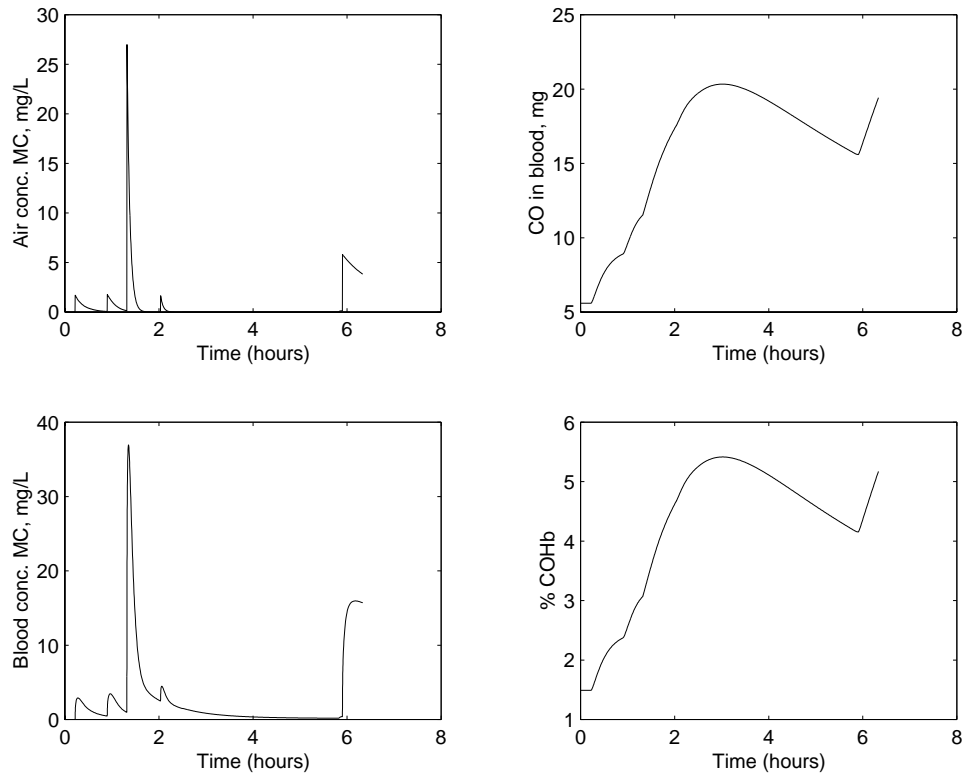

Figure 8 MC air concentration, MC blood concentration, CO in blood and %COHb from 6AM to 12:20PM Adult in room 27; exposure scenario two canisters in room 27

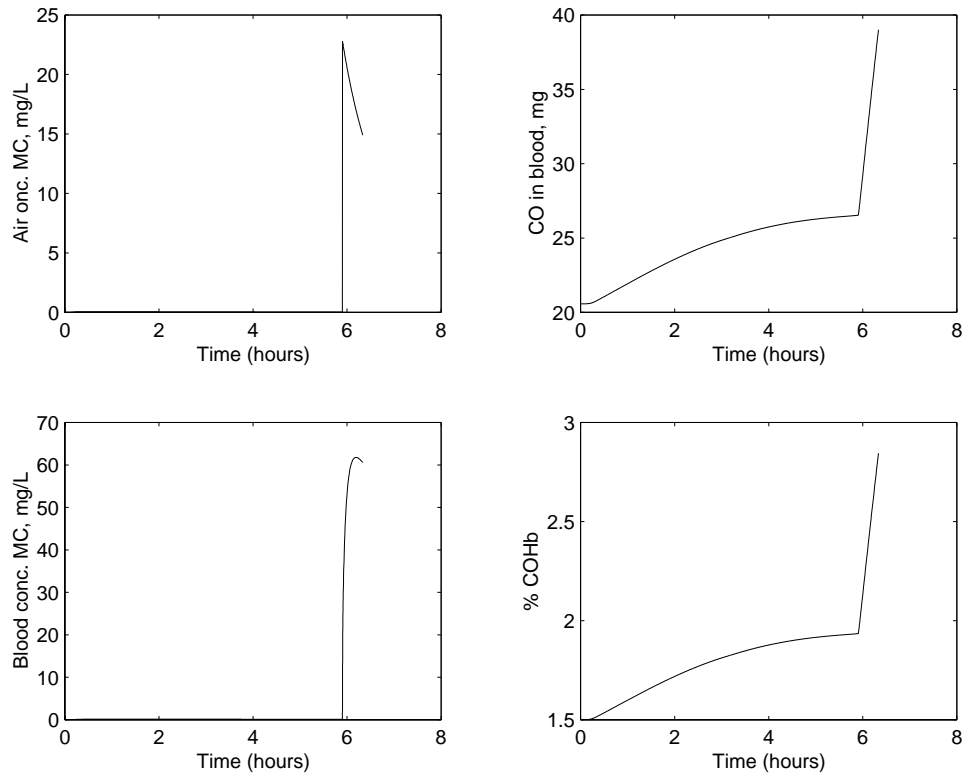

Figure 9 MC air concentration, MC blood concentration, CO in blood and %COHb from 6AM to 12:20PM  
Adult moving from room 19 to room 27 at 8:30; exposure scenario is two canisters in room 27

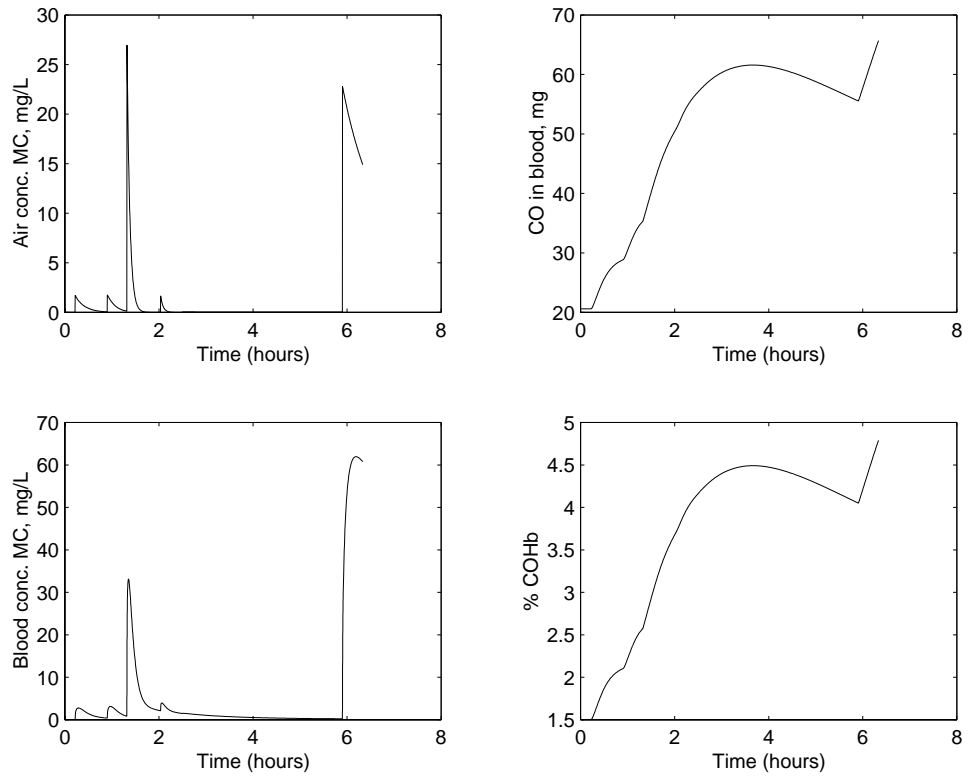

Figure 10 MC air concentration, MC blood concentration, CO in blood and %COHb from 6AM to 12:20PM Adult in room 8; exposure scenario two canisters in room 8

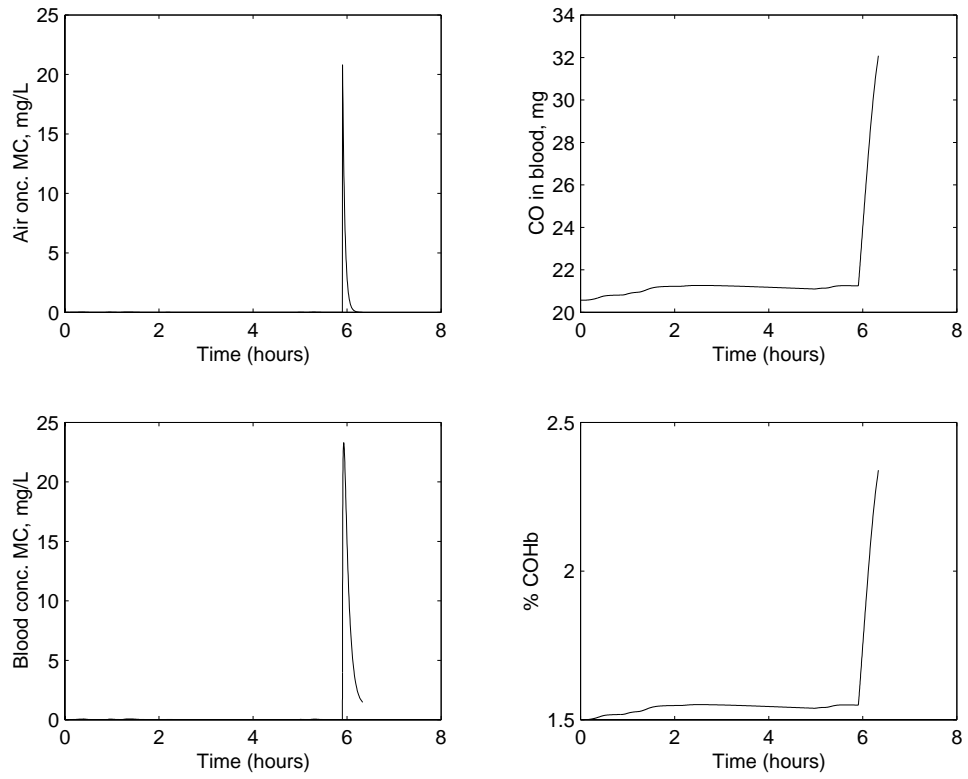



Figure 11 MC air concentration, MC blood concentration, CO in blood and %COHb from 6AM to 12:20PM Adult in room 8; exposure scenario one canister in room 8 and one in room 27

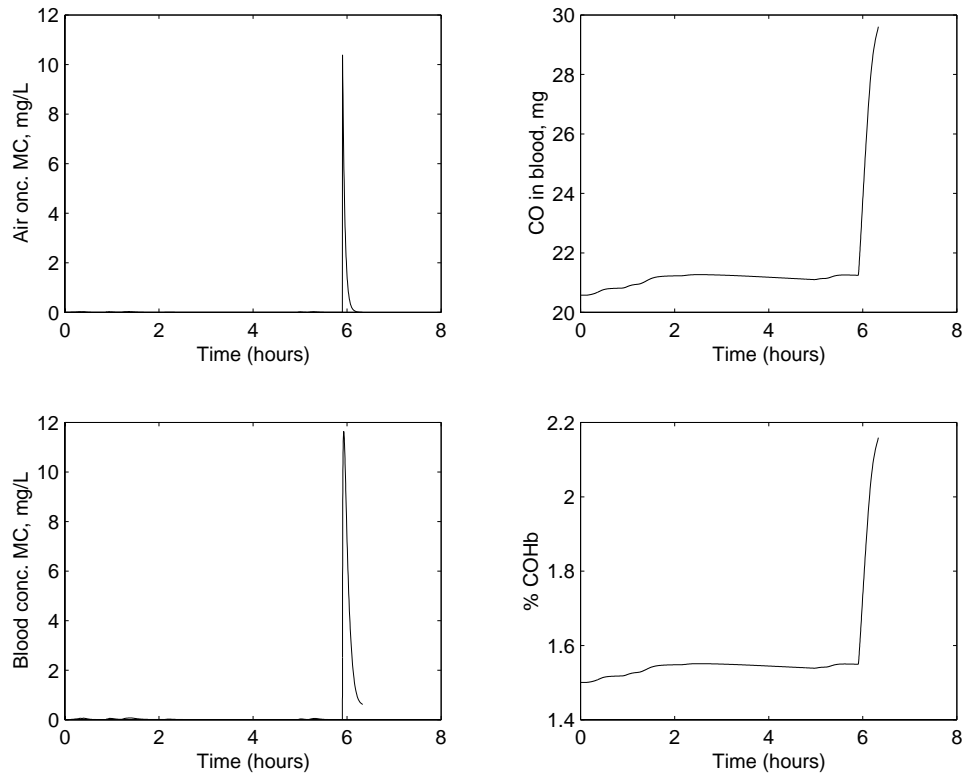

Figure 12 MC air concentration, MC blood concentration, CO in blood and %COHb from 6AM to 12:20PM Adult in room 27; exposure scenario one canister in room 8 and one in room 27

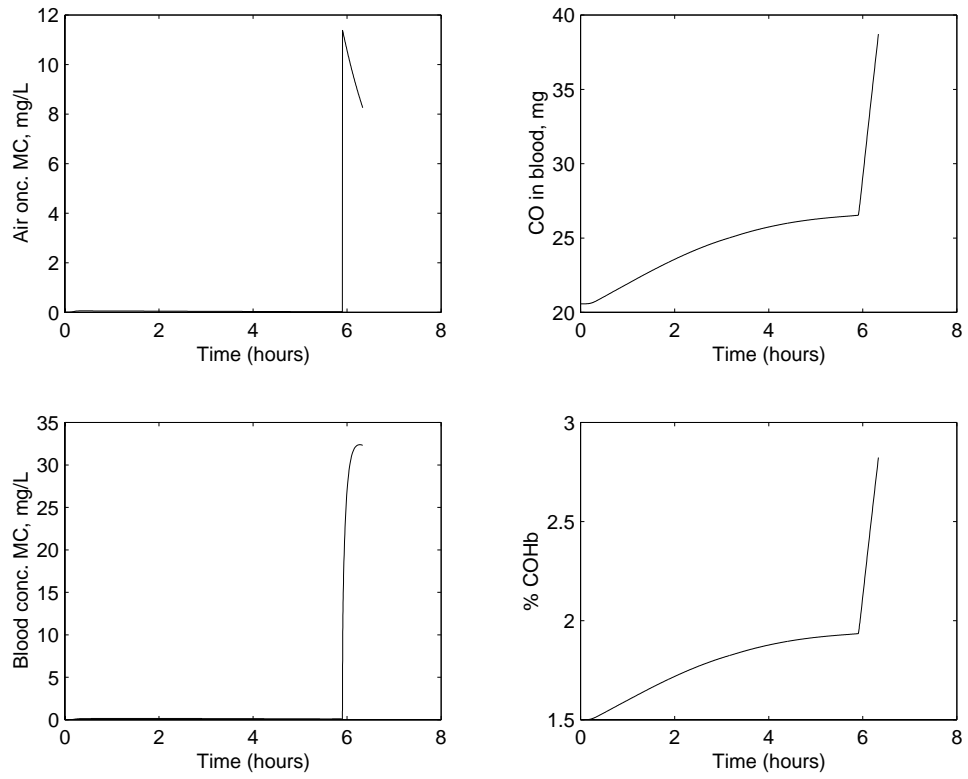

Figure 13 MC air concentration, MC blood concentration, CO in blood and %COHb from 6AM to 12:20PM Adult in room 30; exposure scenario two canisters in room 30

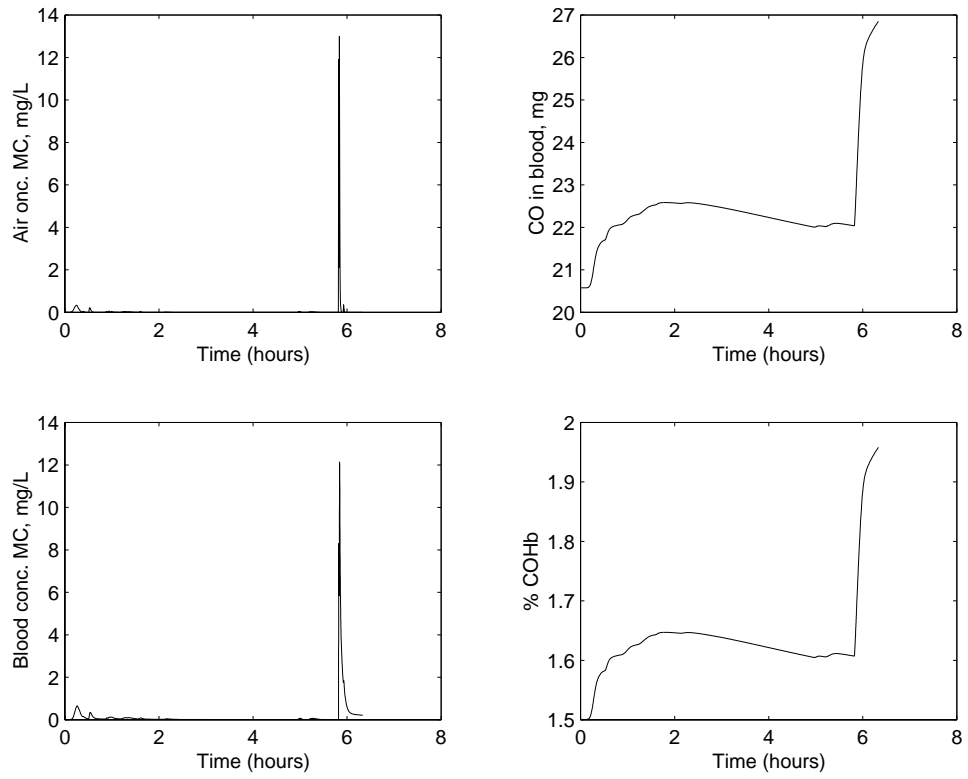
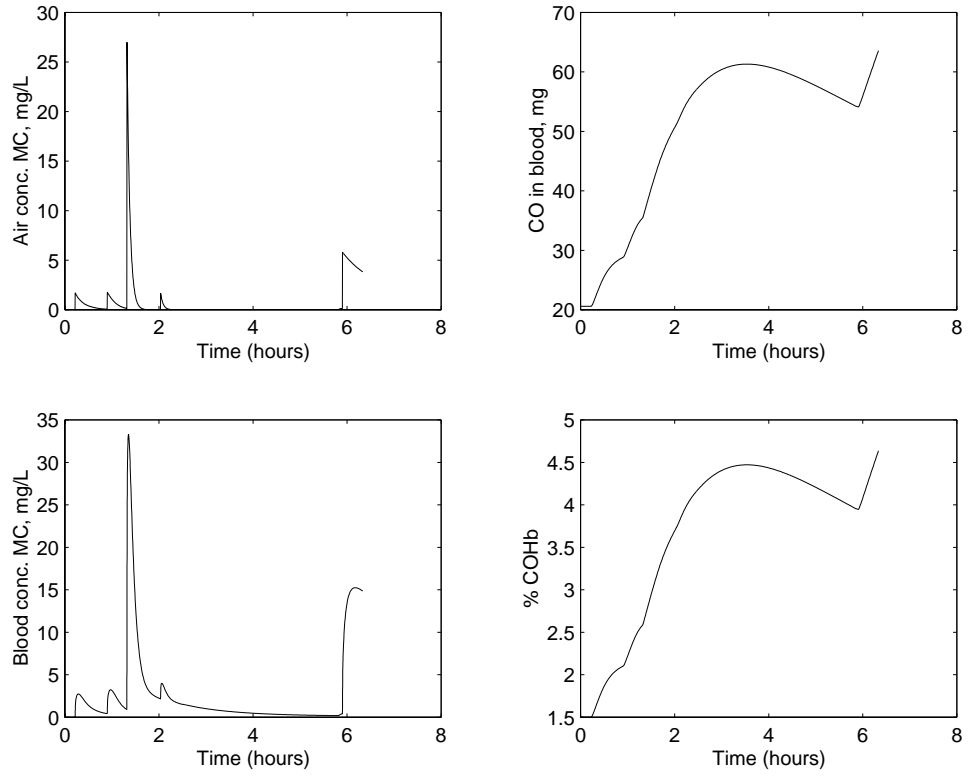

Figure 14 MC air concentration, MC blood concentration, CO in blood and %COHb from 6AM to 12:20PM  
Adult moving from Room 19 to Room 27 at 8:30; exposure scenario 1.5 canisters in room 30 and 0.5 in room 27



# Appendix C

## Physiologically Based Pharmacokinetic Modeling with Dichloromethane, Its Metabolite, Carbon Monoxide, and Blood Carboxyhemoglobin in Rats and Humans

MELVIN E. ANDERSEN,<sup>2,3</sup> HARVEY J. CLEWELL, III, MICHAEL L. GARGAS,<sup>3</sup>  
MICHAEL G. MACNAUGHTON,<sup>4</sup> RICHARD H. REITZ,<sup>4</sup> RICHARD J. NOLAN,<sup>4</sup>  
AND MICHAEL J. MCKENNA<sup>2,3</sup>

*Toxic Hazards Division, Armstrong Aerospace Medical Research Laboratory, Wright-Patterson Air Force Base, Ohio 45433-6573; and \*1803 Bldg., Dow Chemical USA, Midland, Michigan 48640*

*Received January 24, 1990; accepted December 6, 1990*

**Physiologically Based Pharmacokinetic Modeling with Dichloromethane, Its Metabolite, Carbon Monoxide, and Carboxyhemoglobin in Rats and Humans.** ANDERSEN, M. E., CLEWELL, H. J., III, GARGAS, M. L., MACNAUGHTON, M. G., REITZ, R. H., NOLAN, R. J., AND MCKENNA, M. J. (1991). *Toxicol. Appl. Pharmacol.* 108, 14-27. Dichloromethane (methylene chloride, DCM) and other dihalomethanes are metabolized to carbon monoxide (CO) which reversibly binds hemoglobin and is eliminated by exhalation. We have developed a physiologically based pharmacokinetic (PB-PK) model which describes the kinetics of CO, carboxyhemoglobin (HbCO), and parent dihalomethane, and have applied this model to examine the inhalation kinetics of CO and of DCM in rats and humans. The portion of the model describing CO and HbCO kinetics was adapted from the Coburn-Forster-Kane equation, after modification to include production of CO by DCM oxidation. DCM kinetics and metabolism were described by a generic PB-PK model for volatile chemicals (RAMSEY AND ANDERSEN, *Toxicol. Appl. Pharmacol.* 73, 159-175, 1984). Physiological and biochemical constants for CO were first estimated by exposing rats to 200 ppm CO for 2 hr and examining the time course of HbCO after cessation of CO exposure. These CO inhalation studies provided estimates of CO diffusing capacity under free breathing and for the Haldane coefficient, the relative equilibrium distribution ratio for hemoglobin between CO and O<sub>2</sub>. The CO model was then coupled to a PB-PK model for DCM to predict HbCO time course behavior during and after DCM exposures in rats. By coupling the models it was possible to estimate the yield of CO from oxidation of DCM. In rats only about 0.7 mol of CO are produced from 1 mol of DCM during oxidation. The combined model adequately represented HbCO and DCM behavior following 4-hr exposures to 200 or 1000 ppm DCM, and HbCO behavior following 1-hr exposure to 5160 ppm DCM or 5000 ppm bromochloromethane. The rat PB-PK model was scaled to predict DCM, HbCO, and CO kinetics in humans exposed either to DCM or to CO. Three human data sets from the literature were examined: (1) inhalation of CO at 50, 100, 250, and 500 ppm; (2) seven 1-hr inhalation exposures to 50, 100, 250, and 500 ppm DCM; and (3) 2-hr inhalation exposures to 986 ppm DCM. An additional data set from human volunteers exposed to 100 or 350 ppm DCM for 6 hr is reported here for the first time. Endogenous CO production rates and the initial amount of CO in the blood compartment were varied in each study as necessary to give the baseline HbCO value, which varied from less than 0.5% to greater than 2% HbCO. The combined PB-PK model gave a good representation of the observed behavior in all four human studies. This comprehensive model should prove useful for examining coexposures to DCM and CO, for predicting HbCO time courses expected for intermittent exposures to DCM and/or CO, and for developing biological monitoring strategies for these two contaminants based on observed HbCO concentrations after exposure. © 1991 Academic Press, Inc.

Carbon monoxide (CO) is a ubiquitous air contaminant derived primarily from incomplete combustion of hydrocarbon fuels. In addition, CO is produced *in vivo* during the catabolism of heme and during the oxidative metabolism of dihalomethanes except those containing fluorine (Gargas *et al.*, 1986). In the body, CO combines with various hemoproteins and restricts binding of natural ligands such as oxygen. At sufficiently high concentrations, CO acts as a chemical asphyxiant by restricting O<sub>2</sub> binding to hemoglobin and interfering with O<sub>2</sub> delivery to body tissues. At the cessation of CO exposure CO is eliminated from the body by exhalation. In this process, free CO in blood diffuses across the alveolar lining and is exhaled. Various physiological factors govern CO pharmacokinetics: endogenous rate of CO production, concentration of CO in inspired air, O<sub>2</sub> tension, relative affinity of hemoglobin for CO and O<sub>2</sub>, and the diffusing capacity of the lung for CO. Coburn, *et al.* (1965) developed a physiological description of the factors involved in maintenance of blood carboxyhemoglobin (HbCO) in man. The equation which describes the time course of HbCO is called the Coburn-Forster-Kane (CFK) equation and it is of value for restricted applications where most heme is bound with O<sub>2</sub> and endogenous CO production is constant. Peterson and Stewart (1975) subsequently extended the CFK equation to predict HbCO concentrations resulting from CO exposures.

Ramsey and Andersen (1984) described a physiologically based pharmacokinetic (PB-PK) model for the disposition of inhaled volatiles. This model has subsequently been used to examine the kinetic behavior of dichloro-

methane (DCM, methylene chloride) and other dihalomethanes (DHM) (Gargas *et al.*, 1986) and applied in a risk assessment for DCM (Andersen *et al.*, 1987; Reitz *et al.*, 1988). The present work is part of a larger body of research intended to extend the generic PB-PK inhalation model to include analysis of important metabolites. In the case of the dihalomethanes we have modeled the kinetics of CO produced by the oxidation of parent chemicals. This paper outlines the development of a more complete PB-PK model for both CO and blood HbCO which is useful for describing direct CO inhalation, CO produced by endogenous metabolic pathways, and CO produced from dihalomethanes. The CO model was developed following the CFK approach, refined by comparison with HbCO time course data in CO-exposed rats, and scaled to predict human behavior. Predictions in humans were compared to literature data from human volunteers exposed to CO or to DCM and to some human volunteer data presented here for the first time.

## METHODS

*Rats.* Male Fischer 344 rats weighing between 200–250 g were used in all experiments. Rats were maintained on commercially available dry chow and tap water except during periods of exposure when neither food nor water was provided. At all other times rats were kept on a 12-hr light cycle with 40–60% relative humidity.

*Exposures.* All rat exposures were conducted in 31-liter battery jar-type chambers (Leach, 1963). CO was metered through a flow meter from a pressurized cylinder and mixed with chamber input air. Chamber effluent was directed through a long path length IR cell for continuous monitoring of the chamber effluent. The IR was standardized with known concentration CO atmospheres made up by adding measured volumes of CO to Mylar bags and metering air into the bags from a wet test meter. DCM exposures were conducted in the same chambers. Details of the DCM exposures and chamber analysis of DCM have been reported previously (Gargas *et al.*, 1986).

*Blood time course curves.* Blood HbCO concentrations were determined spectrophotometrically by the method of Rodkey *et al.* (1979) using about 5  $\mu$ l blood for the assay. Blood DCM concentrations were determined by GC analysis after extracting a 0.1-ml sample of blood with *n*-hexane. For HbCO determinations, rats were exposed

<sup>1</sup> Presented in part at the 23rd Annual Meeting of the Society of Toxicology, Atlanta, GA (1984).

<sup>2</sup> To whom correspondence should be addressed.

<sup>3</sup> Present address: CIIT, P.O. Box 12137, Research Triangle Park, NC 27709

<sup>4</sup> Present address: Southwest Research Institute, 6220 Culebra Rd., San Antonio, TX 78228-0510.

<sup>5</sup> Present address: Park Davis Pharmaceuticals, Ann Arbor, MI.

for 2 hr, removed from the chamber, and bled serially either by repeated tail tipping with a razor blade or from an indwelling jugular cannula. For DCM analysis, larger blood volumes were required and all of these studies were conducted using cannulated rats.

**Human studies.** The time course data of blood HbCO levels in humans exposed to various concentrations of inhaled CO were obtained from published studies (Stewart, 1975). The data on HbCO, exhaled CO, and blood DCM concentrations in this paper were from studies on human volunteers conducted at the Dow Chemical Co., described below.

In two well-separated studies (2 weeks) six male human volunteers were exposed to DCM vapors at concentrations of 100 or 350 ppm for a period of 6 hr. At designated intervals, samples of blood and expired air were collected for analysis of DCM (blood and air), HbCO (blood), and CO (air). The collection intervals for expired air were 0.25, 0.5, 1, 1.5, 2, 3, 4, 5, and 6 hr during exposure, and 0.083, 0.25, 0.5, 1, 1.5, 2, 3, 6, 8, 16, and 24 hr postexposure. Collection intervals for blood were 3 and 5 (350 ppm) or 6 (100 ppm) hr after initiation of the exposure (during exposure) and 2, 6, 16, and 24 hr postexposure.

Concentrations of DCM in expired air were analyzed by gas chromatography. Concentrations of DCM in blood were analyzed by direct injection of whole blood (1  $\mu$ l) onto gas chromatographic columns with selected ion monitoring ( $m/e = 84, 86$ ). Concentrations of CO in expired air were measured with a specific electrochemical detector (Ecolyzer CO analyzer, Energetics Science, Alford, NY). HbCO measurements in whole blood were performed with a cooximeter.

Additional human DCM exposure data used in the modeling were from 7.5-hr exposures to various DCM concentrations (Peterson, 1975), and from 2-hr high concentration exposures to DCM (Stewart *et al.*, 1972).

**Model development.** The modeling approach used was based on the Coburn-Forster-Kane description of the physiological factors which influence HbCO levels in humans (Coburn *et al.*, 1965), with an additional element to account for CO arising from the oxidative metabolism of DCM. In this description all CO is confined to the blood compartment (Fig. 1) where it partitions between two pools—free and bound (i.e., CO and HbCO). Tissue concentrations of DCM were described with the physiological model developed by Ramsey and Andersen (1984), using metabolic constants for DCM metabolism derived by Gargas *et al.* (1986) for rats or Andersen *et al.* (1987) for humans (Table 1). The essential elements of the PB-PK model were summarized by Gargas *et al.* (1986) and are recapitulated in the Appendix. Constants used in the integrated PB-PK model are summarized in Table 1.

**Blood compartment.** The blood volume was 5.9% of body weight in both rats and humans. Hemoglobin content of blood was 10 mM with respect to heme, a value which is calculated based on an internal erythrocyte heme concentration of about 30 mM. In the equation for the amount

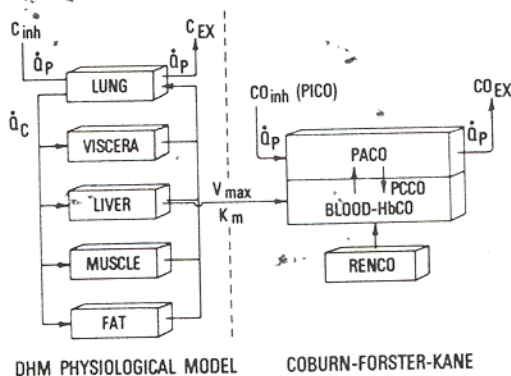

FIG. 1. Schematic of the physiologically based pharmacokinetic description for dihalomethanes and carbon monoxide. Carbon monoxide (CO) is produced by dichloromethane (DCM) oxidation in the liver and is transferred into the blood. CO also enters blood by endogenous production ( $REN_{CO}$ ) and by diffusion across alveolar surfaces in response to a partial pressure difference between the alveolar ( $PA_{CO}$ ) and capillary ( $PC_{CO}$ ) tension of CO. Pulmonary transmembrane CO flux is given by the concentration gradient ( $PA_{CO} - PC_{CO}$ ) times the diffusing capacity of the lung for CO ( $D_L$ ). Inhaled partial pressure of CO ( $PI_{CO}$ ) and the ventilation rate ( $QP$ ) determine the total amount of CO inhaled. Blood CO apportioned between free CO and bound CO (carboxyhemoglobin, HbCO). The appendix has a full description of the equations for the combined DHM-CO model.

of CO in the blood compartment at any time there is an initial amount of CO in the blood ( $AB_{CO}$ ; eq. 2) which is used to establish a background HbCO at the initiation of exposure. CO enters the blood by DCM oxidation, heme catabolism, and inhalation. A generalized mass balance differential equation for the amount of CO in the blood ( $AM_{CO}$ ) is

$$\frac{dAM_{CO}}{dt} = REN_{CO} + METAB * P1 + UPTAKE, \quad (1)$$

where  $REN_{CO}$  is the rate of production of endogenous CO from heme catabolism,  $METAB$  is the rate of oxidation of DCM in the body,  $P1$  is an experimentally derived constant giving the yield of CO/mol DCM oxidized, and  $UPTAKE$  is the rate of direct uptake/elimination of CO in the lung.

**Heme catabolism.** The rate of endogenous CO production ( $REN_{CO}$ ) was adjusted based on the experimental observations to provide an appropriate HbCO background concentration. Based on data of McKenna *et al.* (personal communication) a background HbCO of 0.7% was used in rats. This was achieved with an  $AB_{CO}$  value of 0.117 mg CO/kg body wt and a  $REN_{CO}$  of 12  $\mu$ g CO/rat/hr. This value for  $REN_{CO}$  is higher than that derived experimentally



TABLE 1

PARAMETERS USED IN THE PHYSIOLOGICALLY BASED PHARMACOKINETIC MODEL FOR DICHLOROMETHANE (DCM) AND CARBOXYHEMOGLOBIN (HbCO)

	Human	Rat
<b>Weights</b>		
Body weight (kg)	83.0	0.22
Liver	3.14%	4.0%
Rapidly perfused organs	3.71%	5.0%
Slowly perfused organs	62.0%	75.0%
Fat	23.0%	7.0%
Blood	5.9%	5.9%
<b>Flows (liters/hr)</b>		
Alveolar vent.	395.0	4.89
Cardiac output	331.0	5.20
<b>Flow distribution (% Cardiac output):</b>		
Liver	24%	20%
Rapidly perfused organs	52%	56%
Slowly perfused organs	19%	15%
Fat	5%	9%
<b>Partition coefficients</b>		
Blood/air	8.94	19.4
Liver/blood	1.46	0.732
Rapidly perfused/blood	0.82	0.732
Slowly perfused/blood	0.82	0.408
Fat/blood	12.4	6.19
<b>Biochemical constants<sup>b</sup></b>		
$V_{\max}$ (MFO pathway; mg/hr)	6.25	4.0
$K_m$ (MFO pathway; mg/liter)	0.75	0.4
KFC (GSH pathway; hr <sup>-1</sup> )	2.00	2.00
<b>Carbon monoxide/HbCO constants</b>		
$D_{LC}$ , Diffusion coeff. (liter/hr/mm Hg)	0.058	0.060
$AB_{CO}$ , Amount background CO (mg)	0.300 <sup>a</sup>	0.117
$REN_{CO}$ , Endog. CO prod (mg/hr/kg)	0.15 <sup>a</sup>	0.035
$HB_{TOT}$ , Conc. hemoglobin (mM/liter)	10.0	10.0
$M_{mm}$ Haldane coefficient	234	197
$P1$ , CO yield factor	0.71	0.80
$F1$ , CO elimination factor	0.85	1.21
COINH, Background CO levels (ppm)	2.2 <sup>a</sup>	2.2

<sup>a</sup> Background levels of CO adjusted in studies of Peterson (78) and Peterson *et al.* (1972). See Figure Legends for details. <sup>b</sup>  $V_{\max} = V_{\max C} \cdot (bw)^{0.7}$ ;  $KF = KFC \cdot (bw)^{-0.3}$ .

by Rodkey and Collison (1977) of about 4.5  $\mu$ g CO/rat/hr.

**DCM metabolism.** DCM is metabolized by two pathways only one of which produces CO (Andersen *et al.*, 1987). The equation for DCM consumption in the liver

portion of the DCM model includes both oxidative metabolism and DCM conjugation with GSH (Gargas *et al.*, 1986). To account for CO production the mass flux of DCM through the oxidative pathway (METAB) is multiplied by the ratio of the molecular weight of CO to that of DCM. In addition, Gargas *et al.* (1986) found that only about 70% of the DCM metabolized by microsomal oxidation yields CO, so the constant  $P1$  (Eq. (1)) was set to 0.7 mol of CO produced/mol DCM oxidized in these simulations.

**CO inhalation/exhalation.** The net flux of CO across the lungs is determined by the concentration difference between the arterial capillary partial pressure of free CO ( $PC_{CO}$ ) and the partial pressure of CO in alveolar air ( $PA_{CO}$ ). The amount transferred is determined by the concentration difference ( $PC_{CO} - PA_{CO}$ ) times  $D_L$ , the diffusing capacity of the lungs for CO, and divided by  $RHO$ , the density of CO. Under the conditions in the lungs,  $RHO$  is 1102 mg/liter. The value of  $D_L$  used for the rat, 0.0165 liters CO/hr/mm Hg, is similar to that determined by Takezawa *et al.* (1980) (0.023) using a single-breath method for estimating diffusing capacity.

**CO partitioning in blood.** Both  $O_2$  and CO bind reversibly to hemoglobin with their own individual dissociation constants,  $K_{O_2}$  and  $K_{CO}$ . The ratio of these dissociation constants ( $K_{O_2}/K_{CO}$ ) is called the Haldane coefficient ( $M$ ) and can be used to estimate the relative amounts of blood CO which are bound and free for particular concentrations of total heme,  $O_2$ , and CO. In the lung the alveolar capillary  $O_2$  tension is about 100 mm Hg, which corresponds to an  $O_2$  solution concentration of 0.13 mM. The value of  $M$  used for rat hemoglobin was 197, consistent with determinations by Allen and Root (1957). This value is  $M$  as related to gaseous partial pressures—designated  $M_{pp}$ , in this paper.

**Computational resources.** The physiological model was described by a series of mass balance differential equations plus a number of algebraic relationships. This series of equations was formulated as a computer program and solved numerically with commercially available software packages: either ACSL (Advanced Continuous Simulation Language) or SimuSolv, both of which are commercially available from Mitchell and Gauthier Associates Inc. (73 Junction Square Dr., Concord, MA 01742).

**Model scale-up.** Ramsey and Andersen (1984) previously described the scale-up process from rodents to humans for styrene. In a similar fashion, blood flows in this model were scaled by body weight to the 0.7 power, while alveolar ventilation was scaled to the 0.74 power of body weight. For these studies, metabolic rates for the oxidative pathways were directly set from experimental data in rats and humans (Andersen *et al.*, 1987). In terms of the model for CO and HbCO,  $D_L$  was scaled according to Eq. (2):

$$D_L = D_{LC} * (\text{BodyWt})^{0.92} \quad (2)$$

In this equation  $D_{LC}$  is expressed as either ml/min/mm Hg or liter/hr/mm Hg. The exponent of BodyWt used in

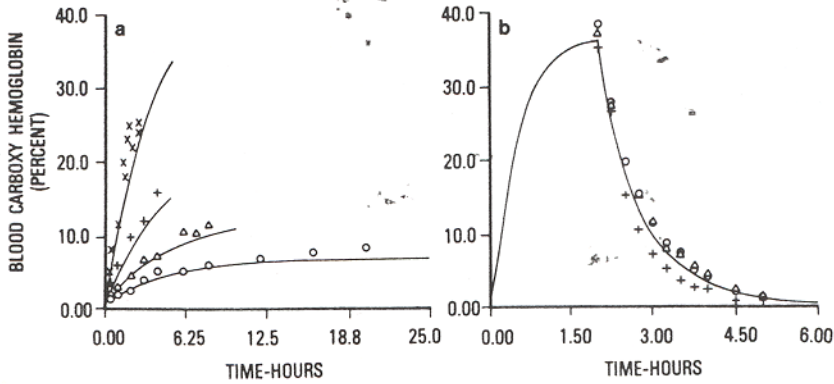

FIG. 2. Blood carboxyhemoglobin concentrations related to carbon monoxide inhalation in human volunteers and in Fisher 344 rats. Human volunteers (a) were exposed to 50, 100, 200, and 500 ppm CO for varying lengths of time. Data (see Stewart *et al.*, 1975) are plotted versus the smooth curve generated from the model. The curves are for 75-kg subjects. (b) Rats were exposed to 500 ppm CO for 2 hr and blood samples were taken serially. Data points are from individual rats (average weight 0.22 kg). In each case physiological parameters were set and the data used to adjust  $M_{pp}$  and  $F1$  to give good correspondence between experimental observations and model predictions.

this equation, 0.92, was estimated from a plot of diffusing capacities in rat, guinea pig, cat, rabbit, dog, and man. The value of  $D_{LC}$  used for rats, 0.06 liter/hr/mm Hg, gives an estimated  $D_L$  value of 0.279 ml/min/mm Hg in a 250-g rat, and the value of  $D_{LC}$  used for humans, 0.058 l/hr/mm Hg, gives a  $D_L$  value of 48.2 ml/min/mm Hg for a 70-kg human. The value of  $D_{LC}$  used for humans is almost twice that used by Coburn, Forster, and Kane (0.03 liters/hr/mm Hg) and is also higher than that predicted by using the allometric equation reported by Stahl (1967). The higher values of  $D_L$  used here were necessary to provide a good description of CO elimination in the rat. An independent determination of  $D_L$  was conducted on a 200-g rat, yielding an observed value of 0.17 ml/min/mm Hg (Newton, unpublished experiments, Wright Patterson Air Force Base, OH, 1982) compared to a calculated  $D_L$  value of 0.227 ml/min/mm Hg. For the other values,  $REN_{CO}$  was scaled to the 0.7 power of body weight while the initial amount of CO in the blood compartment,  $AB_{CO}$ , and the blood compartment volume,  $V_{BL}$ , were scaled to body weight directly.

## RESULTS

*CO inhalation/rats.* An *in vivo* inhalation study was performed in which rats were exposed to 200 ppm CO for 2 hr. Experiments conducted for longer periods of time indicated that the HbCO levels had already reached steady-state at 2 hr. Rats were bled serially at

the end of exposure and the percentage of carboxyhemoglobin in blood was plotted for individual animals (Fig. 2b). This study was used to set two constants in the rat model,  $M_{pp}$  and  $F1$ , which were, respectively, 197 and 1.21 for the rat. The use of an  $F1$  value (Appendix) greater than 1.0 indicated more rapid elimination of CO than expected based on the CFK parameters alone (see Discussion).

*DCM inhalation/rats.* Andersen *et al.* (1987) described the time course of DCM in rats following 4-hr exposures to 200 or 1014 ppm DCM. In these same experiments blood HbCO levels were also determined (Fig. 3). Exposure at 1014 ppm DCM (Fig. 3b) produced peak HbCO levels equivalent to those observed with the 200 ppm exposure (Fig. 3a), but the HbCO levels were still near maximum at 1 hr postexposure. Rats were also exposed to a much higher concentration, 5159 ppm, for  $\frac{1}{2}$  hr and HbCO levels followed for another  $5\frac{1}{2}$  hr (Fig. 4). Peak HbCO levels now occurred at 1–2 hr after the cessation of exposure and were maintained at maximum level until  $2\frac{1}{2}$  to 4 hr postexposure. The physiological model accounted for behavior under all of these conditions as shown by the ability of model predictions (smooth lines) to provide good overall

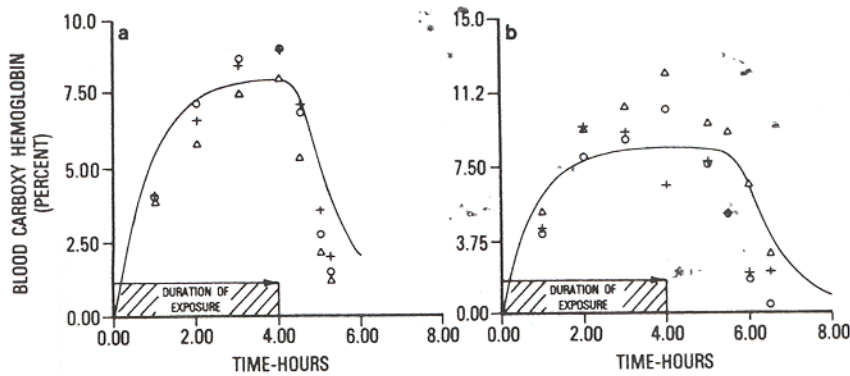

FIG. 3. Blood carboxyhemoglobin (HbCO) concentrations from inhalation of dichloromethane by male Fisher 344 rats. Rats were exposed in groups of three to either (a) 200 ppm or (b) 1014 ppm DCM for 4 hr—represented by the shaded bar. Data are for three rats for each panel bled serially. The maximum metabolic rate ( $V_{max}$ ) for the simulations was 1.46 mg DCM metabolized/rat/hr.

agreement with the shape of the time course curves.

Short duration exposures were also conducted with 5000 ppm bromochloromethane. After adjustment of the metabolic parameters and partition coefficients in the model for this different chemical (see appropriate parameter values in the figure legend), the PB-PK model gave a good description of HbCO levels for up to 6 hr postexposure (Fig. 4) with both of these dihalomethanes.

*CO inhalation/humans.* The rat physiological model was scaled to represent a 83-kg human (Table 1). The model was run at a variety of inhaled concentrations of CO from 50 to 500 ppm and the output of the model was compared with the HbCO percentages observed by Stewart (1975). As with the rat, the scaled model accurately predicted the kinetic properties of CO combination with hemoglobin (Fig. 2a). These simulations used a  $F1$  value of 0.85 and a  $\lambda$  value of 0.058 for  $D_{LC}$  (Table 1). The  $M_{pp}$  value for humans (234) was estimated by multiplying the number used for rats (197) by the ratio of the experimentally determined Haldane coefficients in human blood (230) and in rat blood (190).

*DCM inhalation/humans.* Andersen *et al.* (1987) described the fitting of a DCM time course for humans following exposure to 100 or 350 ppm. This data set was developed at

Dow Chemical Co. with human volunteers in 1982. Data obtained in this study are summarized in Table 2 (concentrations of DCM in whole venous blood), Table 3 (concentrations of DCM in exhaled air), Table 4 (concentrations of CO in exhaled air), and Table 5 (percentages of HbCO in whole venous blood).

Simulations of these data are presented in Fig. 5a (DCM in venous blood) and Fig. 5b

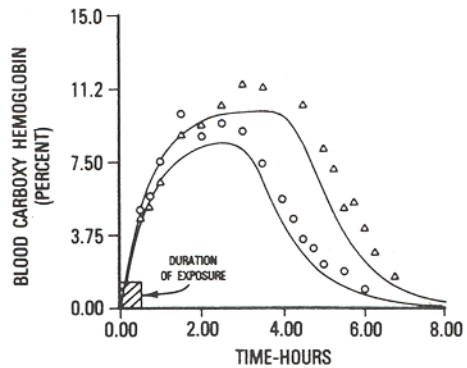

FIG. 4. Blood carboxyhemoglobin levels associated with ½-hr exposures to 5159 ppm dichloromethane or 5000 ppm bromochloromethane (BCM). Data are the average HbCO levels for three rats after pulse exposure, shown by the shaded bar. Triangles are for BCM; circles are for DCM. With BCM,  $V_{max} = 2.77$  mg/rat/hr;  $P_b = 41.4$ ; and  $P_f = 10.0$ . With DCM,  $V_{max} = 1.46$  mg/rat/hr;  $P_b = 19.4$ ; and  $P_f = 6.1$ .

TABLE 2

CONCENTRATIONS OF METHYLENE CHLORIDE (DCM;  $\mu\text{G}/\text{ML}$ ) PRESENT IN VENOUS BLOOD SAMPLES FROM HUMAN VOLUNTEERS EXPOSED TO EITHER 100 OR 350 ppm DCM VAPOR FOR 6 hr

Time (hr)	100 ppm	350 ppm
(Preexposure)	0.005 $\pm$ 0.002	0.016 $\pm$ 0.008
3	1.11 $\pm$ 0.04	5.92 $\pm$ 0.53
5	1.05 $\pm$ 0.10	5.86 $\pm$ 0.49
7	0.15 $\pm$ 0.03	0.91 $\pm$ 0.22
12	0.062 $\pm$ 0.018	0.34 $\pm$ 0.12
22	0.012 $\pm$ 0.005	0.077 $\pm$ 0.039
30	not detected	0.036 $\pm$ 0.020

Note. Times in the table are from the beginning of the 6-hr exposure. Unless otherwise indicated, the results are means  $\pm$  standard deviation from six subjects.

(ppm DCM in exhaled air). In this same experiment exhaled CO and blood HbCO were determined at various times after exposure. Model simulations and experimental data are presented in Fig. 6a (for ppm exhaled CO) and Fig. 6b (percentage HbCO in venous blood). In each case the scaled model predictions matched the overall shape of the time course curves.

Two other data sets from the literature were examined with the current model. Peterson (1975) exposed volunteers to DCM concentrations of 50 to 500 ppm for 7.5 hr and Stewart *et al.* (1972) exposed volunteers to 986 ppm of DCM for 2 hr. The HbCO levels observed in these studies are presented in Fig. 7a (Peterson, 1975) and Fig. 7b (Stewart *et al.*, 1972). Background HbCO was higher in the Dow study (about 2% HbCO) than in the Peterson study (0.4%) or the Stewart study (about 1.5%). In the model background HbCO levels are adjusted by changing  $\text{AB}_{\text{CO}}$  for time zero HbCO, and  $\text{REN}_{\text{CO}}$  for the steady-state HbCO at times after the cessation of exposure.

All time course curves in Figs. 5a, 5b, 6a, 6b, and 7a were obtained with an allometric oxidation rate ( $V_{\text{maxC}}$ ) of 6.25 mg DCM oxidized/hr/kg<sup>0.7</sup>. In the very high concentration exposures (Fig. 7b) the time course curves for the three individuals show extensive variability.

The three smooth curves in this figure are obtained with allometric  $V_{\text{maxC}}$  values of 5.0, 10.0, and 25.0 mg DCM oxidized/hr/kg. This indicates interindividual differences in DCM metabolism. Some of the subjects in this study were using or had been using paint stripping products that contained DCM in their leisure time (personal communication, R. D. Stewart, 1988) which might have caused induction of DCM metabolizing enzymes.

## DISCUSSION

*Physiological modeling.* To the best of our knowledge this work represents the first at-

TABLE 3

CONCENTRATIONS OF METHYLENE CHLORIDE (DCM) AS ppm PRESENT IN EXHALED AIR IN HUMAN VOLUNTEERS EXPOSED TO EITHER 100 OR 350 ppm DCM VAPOR FOR 6 hr

Time (hr)	Exposure concentration	
	100 ppm	350 ppm
0.25	34.6 $\pm$ 5.9	126.3 $\pm$ 12.5
0.50	36.4 $\pm$ 2.3	141.2 $\pm$ 8.3
1.00	39.4 $\pm$ 4.7	155.4 $\pm$ 8.3
1.50	40.4 $\pm$ 5.6	164.9 $\pm$ 7.9
2.00	41.2 $\pm$ 5.1	175.8 $\pm$ 10.1
3.00	41.8 $\pm$ 3.1	192.5 $\pm$ 10.3
4.00	42.8 $\pm$ 3.3	190.3 $\pm$ 14.2
5.00	43.3 $\pm$ 3.6	192.3 $\pm$ 7.1
5.99	45.7 $\pm$ 2.8	201.9 $\pm$ 12.8
6.083	12.1 $\pm$ 0.8	81.3 $\pm$ 11.0
6.25	8.5 $\pm$ 0.7	58.9 $\pm$ 12.1
6.50	6.7 $\pm$ 0.9	38.7 $\pm$ 7.0
7.00	4.2 $\pm$ 1.0	25.1 $\pm$ 7.0
7.50	2.7 $\pm$ 0.6	17.7 $\pm$ 4.1
8.00	2.6 $\pm$ 0.4	14.9 $\pm$ 3.3
9.00	1.8 $\pm$ 0.4	10.3 $\pm$ 3.8
10.00	1.4 $\pm$ 0.6	8.3 $\pm$ 4.0
12.00	nd <sup>a</sup>	4.5 $\pm$ 1.5
14.00	nd <sup>a</sup>	3.2 $\pm$ 1.0
22.00	nd <sup>a</sup>	1.3 $\pm$ 1.0
30.00	nd <sup>a</sup>	nd <sup>a</sup>

Note. Times in the table are from the beginning of the 6-hr exposure. Unless otherwise indicated, the results are means  $\pm$  standard deviation from six subjects.

<sup>a</sup> Not detected.

TABLE 4

CONCENTRATIONS OF CARBON MONOXIDE (ppm) PRESENT IN EXHALED AIR FROM HUMAN VOLUNTEERS EXPOSED TO EITHER 100 OR 350 ppm DCM VAPOR FOR 6 hr

Time (hr)	Exposure concentration	
	100 ppm	350 ppm
0.00	3.8 ± 0.7	4.2 ± 0.7
0.25	5.3 ± 0.5	6.5 ± 0.7
0.50	5.8 ± 0.5	7.6 ± 0.9
1.00	7.0 ± 0.7	10.5 ± 1.8
1.50	8.1 ± 0.9	13.3 ± 2.4
2.00	9.0 ± 0.8	16.1 ± 3.7
3.00	10.7 ± 1.1	20.9 ± 4.3
4.00	13.1 ± 1.6	25.9 ± 6.7
5.00	15.3 ± 2.1	31.1 ± 7.5
5.99	16.8 ± 1.6	36.1 ± 6.1
6.083	17.1 ± 1.3	34.6 ± 7.1
6.25	16.2 ± 1.4	32.5 ± 7.2
6.50	15.8 ± 1.3	32.6 ± 7.1
7.00	15.7 ± 0.6	33.3 ± 7.1
7.50	14.9 ± 1.0	32.3 ± 4.7
8.00	14.6 ± 0.9	30.9 ± 4.5
9.00	11.8 ± 0.6	26.8 ± 4.6
10.00	10.8 ± 0.8	25.1 ± 2.9
12.00	10.0 ± 0.6	21.2 ± 0.8
14.00	9.1 ± 0.7	16.9 ± 2.8
22.00	6.8 ± 0.8	11.8 ± 1.2
30.00	4.3 ± 0.8	5.6 ± 1.1

Note. Times in the table are from the beginning of the 6-hr exposure. Unless otherwise indicated, the results are means ± standard deviation from six subjects.

tempt to provide an integrated physiological pharmacokinetic description of dihalomethane, its metabolite carbon monoxide, and the resulting elevations in HbCO. Gargas *et al.* (1986) used this same model for analyzing the metabolism of dihalomethanes *in vivo* and gave a preliminary description of its essential elements. Steady-state characteristics of the model in terms of expected HbCO levels associated with inhalation of various concentrations of DCM were examined in an earlier communication (Andersen, 1981) which also addressed the interspecies extrapolation of results in one species to predict HbCO concentrations expected in another species. This

present paper is the first detailed description of the CO portion of the combined model, showing its ability to describe existing results for HbCO blood concentrations for both CO inhalation and DCM inhalation in rats and humans.

The development of our combined model followed a relatively straightforward approach. First, the model was developed in its entirety allowing for inhalation of CO, production of CO from DCM oxidation, and endogenous production of CO in the body. This model has many parameters, some of which have been estimated previously by various techniques—such as endogenous CO production (Rodkey and Collison, 1977) or the CO diffusing capacity in a breath holding situation (Takezawa *et al.*, 1980). These literature values serve as starting values in the model which was then refined by analyzing *in vivo* kinetic behavior under conditions where the observed kinetic behavior was essentially determined by just a few of the critical parameters. For instance, the CO inhalation studies are instrumental in setting the Haldane Coefficient, based on

TABLE 5

PERCENTAGES OF HEME PRESENT AS CARBOXYHEMOGLOBIN (HbCO) IN VENOUS BLOOD SAMPLES FROM HUMAN VOLUNTEERS EXPOSED TO EITHER 100 OR 350 ppm DCM VAPOR FOR 6 hr

Time (hr)	Exposure concentration	
	100 ppm	350 ppm
-0.5	1.50 ± 0.19	1.53 ± 0.21
3	3.72 ± 0.40	5.30 ± 0.84
5	5.45 ± 0.42	7.58 ± 1.52
8	4.63 ± 0.44	9.03 ± 1.16
12	3.48 ± 0.50	6.52 ± 0.24
22	2.28 ± 0.44	3.77 ± 0.35
30	1.83 ± 0.30	1.87 ± 0.39

Note. Times in the table are from the beginning of the 6 hr-exposure. Unless otherwise indicated, the results are means ± standard deviation from six subjects. The reading from each subject 0.5 hr before the start of exposure was used as control (i.e., assumed to represent 0% HbCO for each subject).

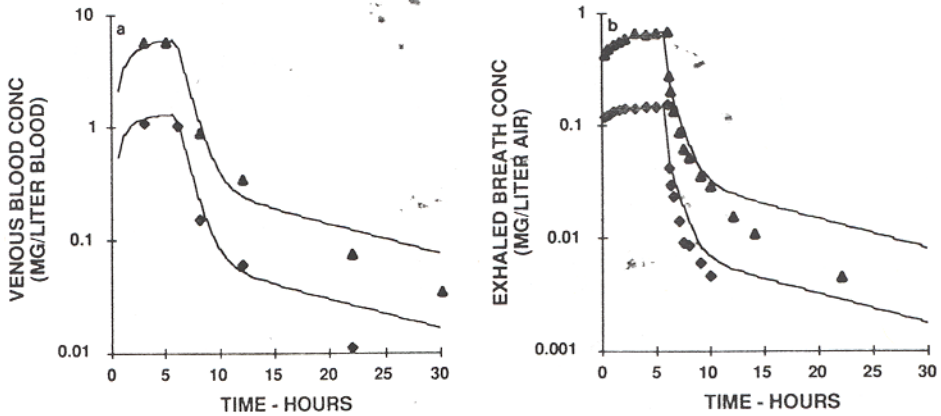

FIG. 5. Human exposure to 50 and 350 ppm dichloromethane: time course of DCM in blood and exhaled breath. Human volunteers were exposed to DCM for 6 hr. Data (Tables 2 and 3) were the average values from six subjects and smooth curves were predicted from the DCM portion of the combined model.

achieved steady-state HbCO, the free breathing CO diffusing capacity, and the adjustment term,  $F_1$ . In the next step the CO/HbCO module was linked with the PB-PK model for the dihalomethanes. In this way the stoichiometric yield term was estimated—that is the mass flux of oxidation was known from previous gas uptake results (Gargas *et al.*, 1986) and the difference between expected and observed CO production was accounted for by

proposing that only 0.7 mol of CO form per mole of DCM oxidized. Two other parameters,  $REN_{CO}$  and  $AB_{CO}$ , the rate of endogenous CO production and the amount of CO in the blood compartment at time zero, were calculated from the model based on experimental observation of background HbCO in the absence of exposure to DCM or CO.

The goal of the entire model development process was to find a single set of parameters

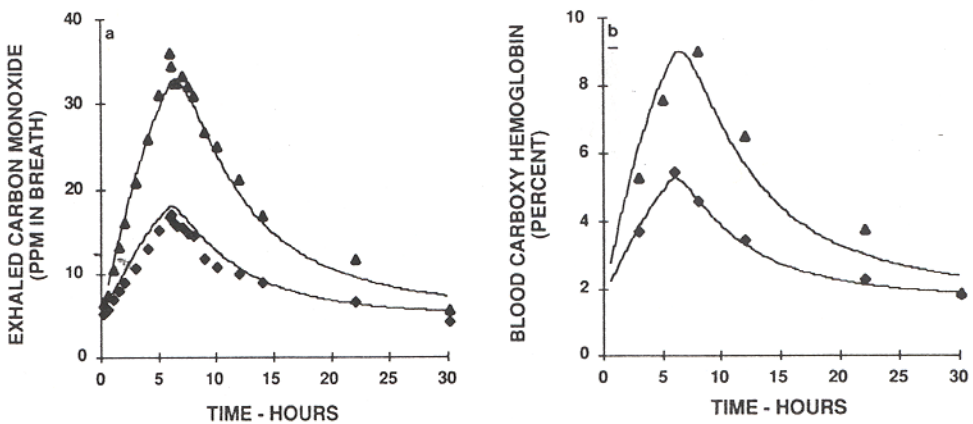

FIG. 6. Human exposure to 50 and 350 ppm dichloromethane: time course of exhaled carbon monoxide and blood carboxyhemoglobin. Exposures are as described in Fig. 5. Data (Tables 4 and 5) are average values from six exposed subjects and the smooth curves were generated from the combined model of DCM and its CO metabolite. The background HbCO of 2% is modeled with  $AB_{CO} = 0.30$  mg;  $REN_{CO} = 0.15$  mg/hr; and background ambient CO concentration = 2.2 ppm.

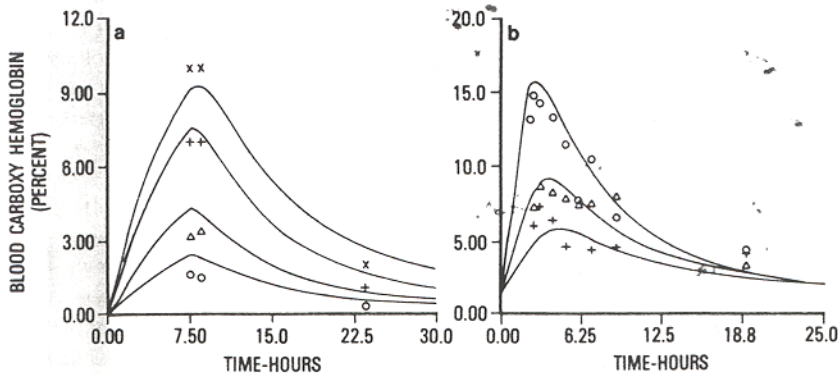

FIG. 7. Blood carboxyhemoglobin in human subjects exposed to dichloromethane. (a) Data from Peterson (1975) for 7.5 hr exposures to 50, 100, 250, or 500 ppm DCM. Data are the average of three observations. (b) Two-hour exposures of individual subjects to 986 ppm DCM (Stewart *et al.*, 1972). The three curves in this panel were generated from three different values of  $V_{\max}$ : 5, 10, and 25 mg/kg/hr. In Panel a as with other human simulations,  $V_{\max}$  was 6.25 mg/kg/hr.

(except for  $REN_{CO}$  and  $AB_{CO}$ ) that would provide a representation of all the available kinetic data in the two species. No global fitting procedure was conducted to "estimate" all the numerous parameters. Fitting of these multi-parameter models to data is best carried out under conditions where the model behavior is determined by a limited number of parameters, such as in those studies noted previously.

The parameters for the DCM model used in this paper differ slightly from those used in other descriptions of this model (Gargas *et al.*, 1986; Andersen *et al.*, 1987). The body weight of test subjects in our human volunteer studies was 83 kg instead of the value 70 kg (Andersen *et al.*, 1987). The other constants in this present paper represent values that give adequate representations of both parent DCM and its CO and HbCO metabolites. The earlier studies focused on DHM in isolation. Another notable difference is that the models of Gargas *et al.* (1986) and our present model do not have a separate lung compartment as did that of Andersen *et al.* (1987). The decision of whether to include a specific organ really is determined by the intended use of the model. The work here only identifies the gas exchange activities and not the xenobiotic metabolizing activities of the lung. Therefore, no formal lung tissue

compartment was deemed necessary in this present work.

With brominated dihalomethanes, another metabolite, the bromide ion itself, was also included in the kinetic model (Gargas *et al.*, 1986). Halide is stoichiometrically produced from each pathway, oxidation and GSH conjugation, and was extremely useful in establishing the individual kinetic constants for these two pathways of DHM metabolism, (Gargas and Andersen, 1982). The present DCM model did not account for chloride ion since it would be difficult to measure this ion against its physiological background concentration. Experiments could be conducted with  $CH_2^{36}Cl_2$  to develop a combined model for DCM, CO, HbCO, and  $^{36}Cl$  ion. This would improve confidence in the choice of the metabolic constants for the two pathways.

The present model should work with all the CO producing DHMs when appropriate values of the kinetic constants and partition coefficients are used (Fig. 7b). Predicted values of HbCO from two different dihalomethanes (Fig. 4) after high concentration exposures were consistent with experimental data.

Another advantage of the combined model is the ability to examine the consequences of

mixed exposure to DCM and elevated CO. At one time, the strategy for setting occupational exposure limits was to keep HbCO less than 5%. Now that DCM has been shown to cause tumors in exposed mice (NTP, 1985), workplace control will probably be related to statistical factors associated with perceived or calculated increased tumor risk (Andersen *et al.*, 1987; Reitz *et al.*, 1988) rather than elevated HbCO.

While the CFK equation handles exponential behaviors at a given concentration of CO, our more complete model is amenable for use with time-dependent changes in inhaled CO. For instance, if work practice analysis provided expected pulsatile CO excursions during the day, these could easily be used as the input function just as time variant DCM concentrations are used to drive the metabolic production of CO in the examples in this present paper.

*Model limitations.* The CFK description of the factors important for controlling circulating HbCO provides a means to integrate the physiological processes governing CO kinetics. Nevertheless, certain simplifying assumptions were made in this approach. These assumptions make the task of writing the model equations easier but may not be completely accurate.

Two important restrictions are that all CO in the body is in the blood compartment and that the blood compartment from which CO diffuses is an arterial compartment where the hemoglobin is fully liganded. The latter assumption is necessary in order to use the Haldane coefficient for calculating the distribution of heme between the two liganded forms, HbCO and HbO<sub>2</sub>. The partial failure of this latter assumption may be reflected in our modeling by the necessity of incorporating an adjustment term  $F1$  in order to modify excretion rates from those expected on the basis of the physiological processes alone (Table 1).

The parameters used give values for  $D_L$ , the diffusing capacity for CO, of almost twice those normally quoted for humans (58 vs 30 ml/min/mm/Hg). The usual method for estimat-

ing  $D_L$ , a single-breath, breath holding maneuver, may indeed produce a different estimate than required during free breathing, the condition of the animals and human volunteers described in the experiments with DCM and CO. While several model constants vary from those in the literature by up to a factor of 2 ( $D_L$  and indirectly  $F1$ ), the model is internally consistent and relies on physiological processes that faithfully reproduce combined behavior in both rats and humans.

As to the problem of the single compartment for CO, the question raised is whether there is a deeper compartment which stores significant amounts of ligand and responds differently than the blood compartment. This question cannot be resolved by the present data. However, the model could easily be expanded to include deeper compartments and saturation exposures could be used to examine the behavior of tissue depots with slow time constants. These experiments should be conducted on individual catheterized rats to enhance their power to resolve slow processes. The present experiments do not provide evidence for significant deep stores which would require modification of the one compartment model for CO distribution.

*Model results/rats.* Rat CO exposures were used to establish certain model parameters ( $M_{pp}$ ,  $F1$ , and to a certain extent  $D_L$ ). These parameters then provide good predictive power for the dihalomethane exposures and the results in humans. At 200 ppm DCM the system is linear (i.e., steady-state HbCO concentrations at 200 ppm are just about twice those observed at 100 ppm) and blood HbCO levels begin to fall immediately at the cessation of exposure. At 1014 ppm DCM the system is saturated (the steady-state HbCO level is virtually unchanged from that at 200 ppm). Now HbCO concentrations remain maximally elevated for a period of time after exposure. This occurs because oxidative metabolism is saturated and blood DCM remains above saturation for over 1 hr postexposure. The blood DCM concentration associated with maximum oxidative rates is estimated by the ratio



of  $V_{\max}/QL$ , liver blood flow (see Andersen, 1981). The ratio is about 1.25 mg/liter with DCM. End exposure blood DCM concentration after a 4-hr exposure to 1014 ppm was about 60 mg/liter, well above saturation.

Another situation examined was high concentration pulse exposure (Fig. 4). Blood HbCO continued to rise after the exposure was terminated. Here DCM oxidation is saturated essentially from the initiation of exposure until the time course curves begin to decline at 3–5 hr, depending on the dihalomethane. However, the half-life for filling the blood compartment with CO is about 1 hr, a time longer than the exposure. The combination of slow filling of the blood CO compartment, persistent presence of saturating DHM at the enzyme, and brief pulse exposure produces maximum metabolite concentrations long after the exposure is completed. A variety of factors are involved in maintaining saturation after the exposure: metabolic constants for DHM oxidation, blood flow to metabolizing organs, blood/air partition coefficients, and fat/blood partition coefficients. The latter is an important parameter since the fat can act as a depot slowly redistributing chemical as blood concentrations fall. The more prolonged elevation of blood HbCO with  $\text{CH}_2\text{BrCl}$  as compared to DCM ( $\text{CH}_2\text{Cl}_2$ ) is associated with several parameters—higher blood/air partition coefficient, higher fat/air partition coefficient, and lower pulmonary clearance (related to the blood/air partition coefficient) for BCM. Values of these parameters can be found in the legend to Fig. 7b.

*Model results/humans.* The human model required a value of  $F1$  less than 1.0 for satisfactory description of the experimental data. The predicted behavior agreed with observed results except that the background HbCO in the present experiments had to be set to a larger value (about 2%) than consistent with expected values for nonsmokers. It is not clear whether our experimental subjects had an input of CO to maintain higher levels of HbCO or if there was a measurement artifact in determining background concentration. Since

HbCO and exhaled CO were both elevated and since both were determined by very different techniques, the increases appear to be real. It deserves mention that the rat model was not developed by examining exhaled CO, yet the PB-PK analysis readily allowed prediction of this parameter for the human exposures.

DCM is a primary constituent of many paint stripping formulations. The production of CO during DCM metabolism was first observed in human studies, not in metabolism studies with experimental animals. Nonsmoking human volunteers were taking part in a controlled study of CO exposures. A participant in the study who had markedly elevated background HbCO was found to be using a DCM paint stripper in the evening before controlled exposure to CO. Increased blood HbCO on the morning after avocational use of DCM is consistent with the kinetics of HbCO seen in rats after a brief pulse exposure to DCM (Fig. 4). Expected behavior in a human was simulated for a 3-hr pulse exposure to 2000 ppm (not shown). Here the peak HbCO level (8%) occurs 8 hr after the exposure. Our model could easily be used to interpret biological monitoring results with blood HbCO. For instance, given an observed HbCO at a particular time after cessation of a DHM exposure of particular duration, the TWA-exposure concentration required to produce the observed level of HbCO could be readily calculated.

*Summary remarks.* A combined PB-PK model has been developed to predict DCM, HbCO, and exhaled CO concentrations in both rat and humans by several routes of administration. This contribution focused on inhalation exposures but the model has also been used to examine intravenous dosing and oral gavage studies with DCM (Andersen *et al.*, 1984). While the purpose of this effort was to combine the DHM and CO descriptions, the model is a complete description of CO behavior and its main utility in the future may well be examining expected HbCO burdens arising from complex occupational CO exposure scenarios.

## APPENDIX

The mass balance differential equation for the amount of CO in the blood compartment consists of three distinct terms:

$$\frac{dAM_{CO}}{dt} = REN_{CO} + \frac{V_{max} * C_{VL} * MW_{CO} * P1}{(K_m + C_{VL}) * MW_{DCM}} - D_L * (PC_{CO} - PA_{CO}) * RHO. \quad (1)$$

$REN_{CO}$  is the endogenous rate of CO production (mg/hr);  $C_{VL}$  is the liver venous concentration of DHM from the PB-PK inhalation model (mg/liter);  $V_{max}$  (mg/hr) and  $K_m$  (mg/liter) are kinetic constants of the oxidative pathway;  $MW_{CO}$  and  $MW_{DCM}$  are the molecular weights of CO and DCM, respectively; and  $P1$  is the portion of the oxidative pathway that yields CO.  $D_L$  is the diffusing capacity of the lung for CO (liter/hr/mm Hg);  $PC_{CO}$  and  $PA_{CO}$  are, respectively, the CO partial pressures in arterial capillary blood and alveolar air (mm Hg); and  $RHO$  is the density of CO at 37°C (mg/liter). In the integral,  $AB_{CO}$ , the constant of integration, is the amount of CO in the blood compartment at the initiation of exposure.

$$AM_{CO} = \int_0^t \frac{dAM_{CO}}{dt} dt + AB_{CO}. \quad (2)$$

The total amount of CO in the blood in milligrams, Eq. (2), is apportioned between bound CO (i.e., HbCO) and free CO, equivalent to  $PC_{CO}$  in the CFK nomenclature. From the definition of the Haldane coefficient in terms of millimolar concentrations of CO in solution,

$$(CO_{free}) = \frac{(O_{2free})(HbCO)}{(M_{mm})(HbCO)}. \quad (3)$$

In the blood we have conservation equations for both total carbon monoxide and total hemoglobin. They are

$$AM_{CO}(mg) = ((CO_{free}) + (HbCO)) * V_{BL} * MW_{CO} \quad (4)$$

$$Hb_{TOT}(mM) = (HbO_2) + (HbCO). \quad (5)$$

Substituting for  $CO_{free}$  and  $HbO_2$  in Eq. (3) produces a relationship for the concentration of carboxyhemoglobin based on the amount of carbon monoxide at any time:

$$(HbCO) = \frac{AM_{CO} / (V_{BL} * MW_{CO})}{(1 + O_{2free}) / (Hb_{TOT} - HbCO)}. \quad (6)$$

Equation (6) could be expressed as a quadratic in (HbCO). In our implementation, it was solved implicitly during the integration. With (HbCO) known,  $(CO_{free})$  and the percentage of carboxyhemoglobin (HbCOPC) are readily calculated.

In the literature the Haldane coefficient is given in terms of partial pressures of  $O_2$  and CO in the gas phase, i.e.,  $M_{pp}$ . The conversion between the Haldane coefficients based on partial pressure and solution concentration is

$$M_{mm} = M_{pp} * \frac{SOL_{O_2}}{SOL_{CO}} * \frac{MW_{CO}}{MW_{O_2}} = 1.313 M_{pp} \quad (7)$$

$$D_L * (PC_{CO} - PA_{CO}) = QP * \frac{(PA_{CO} - PI_{CO})}{P_{AIR}}. \quad (8)$$

Equation (8) gives the two conservation equations for CO in the system stating that the amount crossing the alveolar membrane is equivalent to that net amount retained from inhaled air.

In this equation,  $PI_{CO}$  is the inspired CO pressure,  $P_{AIR}$  is the atmospheric pressure minus the pressure of water vapor at 37°C (713 mm Hg) and  $QP$  is the alveolar ventilation rate (liters/hr). The value used for  $QP$  is the same in both the inhalation PB-PK model for DCM and the CFK model for the inhalation and exhalation of CO. This equation can be rearranged to solve for  $PA_{CO}$ :

$$PA_{CO} = \frac{PC_{CO} + PI_{CO}(QP)/D_L/P_{AIR}}{1 + QP/D_L/P_{AIR}} \quad (9)$$

$PC_{CO}$  is known by difference from Eq. (4) and  $PA_{CO}$  can be calculated directly. The final equations for CO elimination then are

$$CO_{Elim} = D_L * RHO * (PC_{CO} - PA_{CO}) * F_I \quad (10)$$

The exhaled concentration of CO,  $CO_{EXH}$ , was calculated by assuming the pulmonary ventilation was two-thirds of total ventilation.

$$CO_{EXH} = \frac{2}{3} * (CO_{Elim}) / QP \quad (11)$$

## REFERENCES

- ALLEN, T. A., AND ROOT, W. S. (1957). Partition of carbon monoxide and oxygen between air and whole blood of rats, dogs, and men as affected by plasma pH. *J. Appl. Physiol.* **10**, 186-190.
- ANDERSEN, M. E. (1981). Pharmacokinetics of inhaled gases and vapors. *Neurobehav. Toxicol. Teratol.* **3**, 383-389.
- ANDERSEN, M. E., ARCHER, R. L., CLEWELL, H. J., AND MACNAUGHTON, M. G. (1984). A physiological model of the intravenous and inhalation pharmacokinetics of three dihalomethanes— $CH_2Cl_2$ ,  $CH_2BrCl$ , and  $CH_2Br_2$ —in the rat. *Toxicologist* **4**, 111.
- ANDERSEN, M. E., CLEWELL, H. J., GARGAS, M. L., SMITH, F. A., AND REITZ, R. H. (1987). Physiologically based pharmacokinetics and the risk assessment process for methylene chloride. *Toxicol. Appl. Pharmacol.* **87**, 185-205.
- COBURN, R. F., FORSTER, R. E., AND KANE, P. B. (1965). Consideration of the physiological variables that determine the blood carboxyhemoglobin concentration in man. *J. Clin. Invest.* **66**, 1899-1910.
- GARGAS, M. L., AND ANDERSEN, M. E. (1982). Metabolism of inhaled brominated hydrocarbons: Validation of gas uptake results by determination of a stable metabolite. *Toxicol. Appl. Pharmacol.* **66**, 55-68.
- GARGAS, M. L., CLEWELL, H. J., AND ANDERSEN, M. E. (1986). Metabolism of inhaled dihalomethanes *in vivo*: Differentiation of kinetic constants for two independent pathways. *Toxicol. Appl. Pharmacol.* **82**, 211-223.
- LEACH, L. J. (1963). A laboratory test chamber for studying airborne materials. In *AEC Research & Development Report UR-629*, pp. 1-12.
- National Toxicology Program (NTP) (1985). *NTP Technical Report on the Toxicology and Carcinogenesis Studies of Dichloromethane in F-344/N Rats and B6C3F1 Mice (Inhalation Studies)*. NTF-TR-306 (board draft).
- PETERSON, J. E., AND STEWART, R. D. (1975). Predicting the carboxyhemoglobin levels resulting from carbon monoxide exposure. *J. Appl. Physiol.* **39**, 633-638.
- PETERSON, J. E. (1975). Modeling the uptake, metabolism and excretion of dichloromethane by man. *Am. Ind. Hyg. Assoc. J.* **39**, 41-47.
- RAMSEY, J. R., AND ANDERSEN, M. E. (1984). A physiologically based description of the inhalation pharmacokinetics of styrene in rats and humans. *Toxicol. Appl. Pharmacol.* **73**, 159-175.
- REITZ, R. H., MENDRALA, A. L., PARK, C. N., ANDERSEN, M. E., AND GUENGERICH, F. P. (1988). Incorporation of *in vitro* enzyme data into the physiologically based pharmacokinetic (PB-PK) model for methylene chloride: Implications for risk assessment. *Toxicol. Lett.* **43**, 97-116.
- RODKEY, R. F., AND COLLISON, H. A. (1977). Effect of dihalogenated methanes on the *in vivo* production of carbon monoxide and methane by rats. *Toxicol. Appl. Pharmacol.* **40**, 39-47.
- RODKEY, R. F., HILL, T. A., PITTS, L. L., AND ROBERTSON, R. F. (1979). Spectrophotometric measurement of carboxyhemoglobin and methemoglobin in blood. *Clin. Chem.* **25**, 1388-1393.
- STAHL, W. R. (1967). Scaling of respiratory variables in mammals. *J. Appl. Physiol.* **22**, 453-460.
- STEWART, R. D., FISHER, T. N., HOSKO, M. J., PETERSON, J. E., BARETTA, E. D., AND DODD, H. C. (1972). Experimental human exposure to methylene chloride. *Arch. Environ. Health* **25**, 342-348.
- STEWART, R. D. (1975). The effect of carbon monoxide on humans. *Annu. Rev. Pharmacol.* **15**, 409-423.
- TAKEZAWA, J., MILLER, F. J., AND O'NEIL, J. J. (1980). Single-breath diffusing capacity and lung volumes in small laboratory mammals. *J. Appl. Physiol.: Respir. Environ. Exercise Physiol.* **48**, 1052-1059.

# Appendix D

## Co-Editor in Chief Lucier Retires

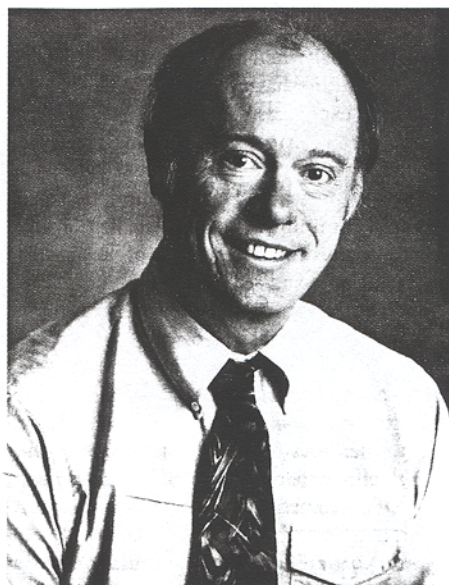

Public service. It's a term that has fallen into disregard in recent years as cynicism has replaced optimism about so-called government work and those who do it. Yet there are those who have chosen to follow the ideal of public service espoused by John F. Kennedy when he said "[A]sk not what your country can do for you, ask what you can do for your country." One of these people is George W. Lucier, an environmental health research pioneer and co-editor in chief of this journal for the past 28 years. In 1970, Lucier chose to devote his intellectual talents to a career in science at a federal research institution, the NIEHS. What developed over the next 30 years of his career was a series of contributions to public health that reached beyond national boundaries. At the end of June, Lucier officially retired from his position as director of the Environmental Toxicology Program, the NIEHS program that executes the work of the National Toxicology Program (NTP), and as co-editor in chief of *EHP*. But the consequences of his leadership and life's work continue to be felt far beyond the epicenter of his career.

Lucier began his career by helping to mold basic science into tools for solving the complex problems created by an industrial society's impact on the natural world and human health. This work has been concentrated most significantly in two areas: the establishment of research models that use molecular epidemiology to obtain better measures of exposure to environmental agents and the use of receptor-mediated toxicology in understanding low-dose effects of chemicals.

In the early 1980s, Lucier began to examine the way that epidemiology was used to formulate estimates of exposure. His early research in the areas of benzene, polycyclic aromatic hydrocarbons, and dioxins formed the basis for new research models that have been accepted by scientists around the world. These models, which bring the tools of molecular epidemiology to bear on the process of human sampling and biochemical analysis of such samples to create better indications of human exposure to toxic substances, have become a benchmark for determining how animals and people respond to environmental insult. Consequently, this information is now commonly used to form the basis for human risk assessment and regulatory decisionmaking.

In the 1990s, Lucier continued to expand the scientific basis for risk assessment when he joined efforts with NIEHS biomathematician Chris Portier to transform science's understanding of receptor-mediated toxicology. Prior to this, chemical risk assessments were almost universally based on overly simplistic threshold or linear dose-response models. Lucier and Portier used their knowledge of the mechanisms of action of dioxins and environmental estrogens to develop laboratory strategies for understanding the low-dose effects of these, and subsequently other chemicals. This understanding of low-dose effects has revolutionized the way that scientists, regulatory agencies, and the public have come to view the dangers of toxic chemicals and other environmental agents. In particular, the mechanistic approach has been utilized through Lucier's involvement in an almost eight-year process by the U.S. Environmental Protection Agency to reevaluate the risk of human exposure to dioxin. This review, which is nearing completion, produced credible biologically

based models for estimating risk and will doubtless be used as a model for determining the hazards posed by other agents.

In recent years, Lucier's attention has been focused precisely on this problem of evaluating chemical and environmental agents for their effects on human health. In 1993, he assumed the directorship of the NIEHS Environmental Toxicology Program and began to transform the NTP from a program focused almost exclusively

on traditional carcinogenicity and toxicity tests to one that sets the gold standard for toxicity evaluation by combining animal data with mechanistic approaches to evaluating human exposures. His mantra and that of the NTP became "good science for good decisions."

Recognizing that the purpose of the NTP is to serve public health, Lucier set about creating a framework for decisionmaking that incorporates multiple stakeholders including state and federal scientific and public health agencies, industry, and public interest and environmental organizations into the process with a focus on the consideration of a variety of inputs, open communication, and public accountability for both the process and the final decisions that are made as a result. His recognition that government-funded science cannot operate in isolation but must be shown to be appropriate, justified, and responsive to public health priorities has taken the NTP from a largely parochial program based at the NIEHS to a truly national endeavor toward solving major environmental health questions. Ways in which this is being accomplished include the establishment of NTP centers for the evaluation of reproductive risks, the validation of alternative test methods in toxicology, and the investigation of phototoxicology.

In turn, Lucier has taken the approaches developed in the NTP and applied them to major global health issues as well. For example, his work on a World Trade Organization scientific panel on the potential health effects of growth promoters in livestock helped to set a precedent for the use of health risk assessments in making international trade decisions. And his skills as a scientist, a negotiator, and a consensus-builder were used to ultimate advantage in brokering a level of agreement among various federal agencies over what are considered safe levels of methylmercury in our environment.

In conjunction with the multitude of his other duties, Lucier helped to lead *EHP* in its evolution from a series of monographs into a truly global science journal devoted to promoting environmental health through the communication of credible, timely, and understandable research and information.

Perhaps Lucier's greatest achievement, however, has been his ability over the years to inspire those who have had the opportunity to work with him and witness his devotion to public health to take up the mantle of public service themselves, to the betterment of the planet and all its people.

**Kimberly G. Thigpen**  
News Editor, *EHP*



*Environmental health is a discipline that can stimulate our best instincts to be considerate of all people and creatures on this planet.*

## Parting Thoughts

It has been said that there is no stronger urge than the urge to edit someone else's writing. Upon my retirement from the National Institute of Environmental Health Sciences (NIEHS), and concurrently from my position as co-editor-in-chief of *Environmental Health Perspectives*, I find that perhaps the stronger urge is not to edit but rather to editorialize. Therefore, I would like to provide some parting thoughts, and with them hopefully some insights gained from my experiences, which have spanned the broad spectrum of environmental health, from basic science to public health policy to science communication. In a 30-year career in environmental health, I have witnessed the expansion of the field as both a scientific discipline and a global movement. In looking forward, I feel that there are some major components which environmental health must enthusiastically encompass if it is to continue to provide real answers to some of the most pressing issues of our day.

Mechanism-based toxicology must be the centerpiece of any effective strategy for meeting the challenges of providing the public with better answers to complex public health questions. Clearly, the controversies that surround dose-response relationships, selection of appropriate models for extrapolating human responses to environmental insult, and the factors that are responsible for interindividual variations in susceptibility to adverse health effects can only be addressed if we make appropriate use of new technologies and our exploding knowledge of fundamental biologic processes. Yet, we should not become unthinking and arrogant slaves to the technology itself. Instead, we must employ sound scientific judgment in asking the right questions and in interpreting the results in a credible fashion.

As part of this process, we must continue to lessen our use of animals in environmental health research. The impressive development of cell-based toxicology systems offers the opportunity to achieve a panel of toxicity tests that are faster, more sensitive, more specific, and cheaper than existing long-term bioassays in rodents or other species for assessing cancer and other effects. Although I agree that we must seize this opportunity to diminish our reliance on animal bioassays, I expect that decreased animal usage will be gradual and will continue into the foreseeable future if we are to meet our mandates of public health protection.

Just as we look to the common physiologies of people and animals for health answers, so should we look to the common ground between human and ecologic health. We often drift away from the concept of the connections between humans and their total environment, and, in doing so, we inappropriately narrow our perspective. Most of the major environmental health issues of our day, including global warming, endocrine disruptors, the causes of malformed frogs, and toxic organisms such as *Pfisteria* emphasize the need to seek and define this common ground in our research strategies and in our health policy decisions.

With these goals comes the inevitable realization that resources of all types—time, money, and humans—are limited and thus, priorities must be set. It has been said that you can have it all, just not at the same time, and I believe this to be true. What this means is that we have to choose well in setting environmental health priorities if we are to make the best uses of the resources available to us. This is often

an extremely difficult task. For example, setting testing priorities for the National Toxicology Program (NTP) presents a host of challenges; there are 80,000 chemicals in commerce today, many of which have not undergone adequate toxicologic evaluation. The question is, of course, where to begin. Among our top priorities for toxicologic evaluation, we must include DNA-based products, herbal medicines, chemical mixtures, and phototoxicity.

In performing such evaluations, as with all environmental health research, we must adopt a multidisciplinary approach to research. Many times the invocation to multidisciplinary research is often merely rhetoric and does not represent a true desire to understand a different perspective. My hope is that the critical environmental issues of our day will foster effective interactions among disciplines and that all stakeholders, be they basic scientists, toxicologists, mathematicians, epidemiologists, risk assessors, ecologists, public health officials, or public citizens, will work together to achieve environmental health gains. To do this we must always strive for objectivity, work toward consensus, never disdain negotiation, and acquire an understanding of the diverse points of view that surround environmental health issues.

Preparation for these efforts requires training. Such training poses unique challenges because of the extraordinarily broad scope of activities and disciplines housed under the umbrella of environmental health research. However, progress in such research and its linkage to public health policy demands a significant and sustained training effort by the NIEHS and other federal agencies. Senior scientists and managers must take their mentoring responsibilities seriously and provide to their employees real opportunities to learn in an atmosphere that fosters creativity, goodwill, and a sense of service.

This is especially true for those who work for public scientific agencies and organizations. We must remember who pays our salaries and funds our research, and guard against becoming nonresponsive to public concerns over environmental and health issues. We must remember that the public has a right to know, and we have an obligation to provide understandable information on what we do, why we do it, and what we think it means; and to listen and change what we do when called upon by our "real bosses." Environmental health institutions must recognize that communication is a two-way street, best served by effective interactions throughout an entire process be it regulatory decision making or formulation of scientific strategies, not just the reporting of a decision at the end. To facilitate this process, journals such as *EHP* have an obligation to provide accurate and understandable information on important issues in a timely manner.

In making the decision to come to the NIEHS and to stay here for 30 years, I have been privileged to work with those at the NIEHS, as well as many agencies, organizations, and institutions in the United States and abroad, on the common goals of global human health and a healthy environment. As my final parting thought, I would like to thank the dedicated, talented, and hard-working people who have made environmental health a discipline that can stimulate our best instincts to be considerate of all people and creatures on this planet.

George W. Lucier  
Co-Editor-in-Chief, *EHP*

09/02/99

CURRICULUM VITAE

Name: George Wayne Lucier

Date and Place of Birth: June 23, 1943, Southbridge, Massachusetts

Citizenship: United States

Education:

June 1961 - Graduated from High School  
June 1965 - B.A. (Biology), Clark University, Worcester, Massachusetts  
Feb. 1968 - M.S. (Entomology), School of Agriculture, University of Maryland  
June 1970 - Ph.D. (Entomology), School of Agriculture, University of Maryland

Brief Chronology of Employment:

1965 - 1970 Graduate Assistant, Department of Entomology, University of Maryland  
1970 - Date National Institute of Environmental Health Sciences, Research Triangle Park, North Carolina  
1970 - 1972 Staff Fellow  
1972 - 1974 Senior Staff Fellow  
1974 - Date Research Chemist  
1979 - 1980 Acting Chief, Laboratory of Organ Function and Toxicology  
1981 - 1984 Head, Section on Receptor Pharmacology, Laboratory of Pharmacology  
1984 - 1996 Chief, Laboratory of Biochemical Risk Analysis, Division of Intramural Research  
1993 - Date Director, Environmental Toxicology Program, National Institute of Environmental Health Sciences -- Senior Executive Service

Bio Sketch

Dr. George W. Lucier is Director, Environmental Toxicology Program, at the National Institute of Environmental Health Sciences (NIEHS) and in that capacity is establishing new directions for the National Toxicology Program, the nation's most comprehensive toxicology testing program. He also serves as Chairman of the Scientific Advisory Board for regulation of toxic air pollutants by the State of North Carolina. Dr. Lucier has been a researcher at NIEHS since 1970, and his research group focuses on molecular epidemiology and dosimetry. His recent work is attempting to use fundamental knowledge to reduce uncertainty in risk estimates of endocrine disrupting chemicals. He is widely recognized for his work in the areas of steroid action, mechanisms of dioxin toxicity, and xenobiotic metabolism, and has published more than 200 articles in these areas. During the last 10 years, he has helped to forge the emerging areas of molecular

epidemiology and the development of laboratory approaches to improve the risk assessment process and in this capacity, he frequently advises Federal and state agencies on high visibility human health risk assessments. He received his Ph.D. from the School of Agriculture, University of Maryland, College Park. He also serves as Co-Editor-in-Chief of *Environmental Health Perspectives*.

Editorial Responsibilities:

1973 - Date      Co-Editor, *Environmental Health Perspectives*, National Institute of Environmental Health Sciences

Societies:

American Society for Pharmacology and Experimental Therapeutics  
Society of Toxicology  
American Association for the Advancement of Science  
Endocrine Society  
American Association for Cancer Research

Major Awards:

NIH Director's Award for research excellence in perinatal aspects of toxicology, pharmacokinetics and enzymology, June 1978.  
NIH Award of Merit for Scientific Excellence, 1986.  
Outstanding Performance Awards - 1990, 1991, 1992, 1993, 1994, 1995, 1996  
Senior Executive Service Performance Awards – 1997, 1998  
NIH Director's Award for developing partnerships in environmental health and risk assessment, June 1997.

Academic Activities:

Adjunct Faculty Member, University of North Carolina, Department of Biochemistry and Nutrition, 1977 - Date  
Faculty Member, University of North Carolina Curriculum in Toxicology (Ph.D. Granting Program) and University of North Carolina Toxicology Training Program, 1980 - Date  
Doctoral Dissertation Committee, Dr. Winifred Curley, University of North Carolina, Department of Biochemistry and Nutrition (Ph.D. awarded 1983)  
Doctoral Dissertation Advisor and Chairman of Dissertation Committee, Dr. Claudia Libman Thompson, University of North Carolina, Department of Biochemistry and Nutrition, 1978 - 1982 (Ph.D. awarded May, 1982)



Academic Activities: (continued)

- Doctoral Dissertation Advisor and Chairman of Dissertation Committee, Dr. Diane Campen, University of North Carolina, Curriculum in Toxicology, 1982 - 1988 (Ph.D. Awarded, 1988)
- Doctoral Dissertation Advisor and Chairman of Dissertation Committee, Dr. Tamra Goodrow, University of North Carolina, Curriculum in Toxicology, 1986 - 1989 (Ph.D. Awarded, 1989)
- Doctoral Dissertation Committee, Dr. James Conway, University of North Carolina, Curriculum in Toxicology, 1981 - 1984 (Ph.D. awarded 1984)
- Doctoral Dissertation Committee, Dr. Jane Gallagher, University of North Carolina, School of Public Health, 1984 (Ph.D. awarded, 1986)
- Doctoral Dissertation Committee, Dr. Susan Borghoff, University of North Carolina, School of Public Health, 1984 - 1987 (Ph.D. awarded, 1987)
- Doctoral Dissertation Committee, Dr. Dennis Chapman, University of North Carolina, Curriculum in Toxicology, 1985 - 1988 (Ph.D. awarded, 1987)
- Doctoral Dissertation Advisor and Chairman of Dissertation Committee, Dr. Jay Goldring, University of North Carolina, Curriculum in Toxicology, 1987 - 1990 (Ph.D. awarded, 1990)
- Doctoral Dissertation Committee, Dr. Beth Mileson, University of North Carolina, Curriculum in Toxicology, 1987 - 1989 (Ph.D. awarded, 1989)
- Doctoral Dissertation Advisor and Chairman of Dissertation Committee, Dr. Charles H. Sewall, University of North Carolina, Curriculum in Toxicology, 1991 - 1994 (Ph.D. awarded, 1994).
- Biochemical Toxicology Course; Lectures on Teratology, Toxicokinetics, Toxicant-Receptor Interactions, Conjugation Reactions, Physiological Factors Affecting Metabolism and Biochemical Risk Assessment, University of North Carolina, Department of Biochemistry and Nutrition (Graduate School), 1979 - Date
- Chairman, Grant Proposal Review Committee for Dr. Will Harrelson, University of North Carolina, Department of Biochemistry and Nutrition, 1982
- Introduction to Research in Biochemistry Course, University of North Carolina, Department of Biochemistry and Nutrition, 1978 - Date
- Chairman, Written Exam Committee for Graduate Students, University of North Carolina Curriculum in Toxicology, 1984.
- Executive Committee, University of North Carolina Curriculum in Toxicology, 1984 - 1987.
- Doctoral Dissertation Advisor and Chairman of Dissertation Committee, Mr. Michael Wyde, University of North Carolina, Curriculum in Toxicology, 1998 - Date.
- Doctoral Dissertation Advisor, Ms. Amy Kim, University of North Carolina, Curriculum in Toxicology, 1998 - Date.

Invited Seminars, Presentations, Symposia: (1988 - Date)

Seminar to Worcester Foundation for Experimental Biology, "Molecular Approaches in Epidemiology and Risk Assessment", March, 1988.

Co-Organizer of Symposium on "Benzene Metabolism Toxicity and Carcinogenesis, Research Triangle Park, March, 1988.

Seminar to Texas A and M University, Department of Pharmacology, "Placental Markers of Human Exposure to Environmental Chemicals", April, 1988.

Presentation to American Chemical Society Symposium on Biological Markers of Environmental Contaminants "Placental and Lymphocyte Markers of Human Exposure to PCBs and PCDFs, Los Angeles, California, September, 1988.

Panel presentation to Workshop on "Interspecies Extrapolation" sponsored by the American Board of Toxicology and Society of Risk Analysis, October, 1988.

Presentation to Symposium on Assessment of Inhalation Hazards: Integration and Extrapolation Using Diverse Data "Molecular Dosimetry in Risk Assessment", Hannover, Federal Republic of Germany, February, 1989.

Presentation to Workshop on Experimental and Epidemiologic Applications to Risk Assessment of Complex Mixtures "Placental Markers of Human Exposure to PCBs and PCDFs, Espoo, Finland, May, 1989.

Presentation to Gordon Conference on Toxicology "Interactions of TCDD with Receptors", Kimball Union, New Hampshire, July, 1989.

Presentation to International Life Sciences Institute Regional Risk Assessment Workshop, "Overview of Biomarkers", Chicago, Illinois, June 1989.

Presentation to NIH Workshop on Hormonal Carcinogenesis, "Liver Models of Estrogen Induced Carcinogenesis", Gaithersburg, Maryland, September, 1989.

Presentation to SETAC symposium on Long-Term Effects of Bioaccumulated Polyhalogenated-Hydrocarbons, "Placental Markers of Human Exposure to PCBs and PCDFs: Implications for Risk Assessment", Toronto, Canada, October, 1989.

Presentation to NIH workshop on Human Health Effects of Halogenated Biphenyls and Related Compounds, "Effects of Halogenated Aromatics on Multiple Receptor Systems in Animal Models and Human Tissues", Ann Arbor, Michigan, November, 1989.

Invited Seminars, Presentations, Symposia: (continued)

Presentation to Society of Toxicology Symposium on Comparative Dosimetry of Inhaled Materials: Differences Among Animal Species and Extrapolation to Man, "Biomarkers of Dose of Inhalants", Miami, Florida, February, 1990.

Presentation to Symposium on Application of Molecular Markers in Epidemiology, "Relationships Between Various Markers of Genetic Damage in Blood Cells", Research Triangle Park, North Carolina, February, 1990.

Seminar to N.C. State University, "Interactions of TCDD and its Structural Analogs with Multiple Receptor Systems", Raleigh, North Carolina, April, 1990.

Seminar to Chemical Industry Institute for Toxicology, "Role of Estrogens in Promotion of Liver Tumors by TCDD in Rats, Research Triangle Park, North Carolina, June, 1990.

Discussant to Third International Conference on the Use of Human Cell, Tissues and Organs in Research", Washington, D.C., September, 1990.

Seminar to Washington State University Pharmacology Department on "Ovarian Hormones are Essential for TCDD Hepatocarcinogenicity," Pullman, Washington, September, 1990.

Presentation to Banbury Conference on the Biological Basis for Risk Assessment of Dioxin and Related Compounds, "Dioxin and tumor promotion", Cold Spring Harbor, NY., October, 1990.

Presentation to Society for Risk Analysis "Animal Studies on TCDD and Related Compounds: Toxic and Biochemical Effects", New Orleans, Louisiana, October, 1990.

Presentation to Society of Toxicology Symposium on "Assessment of Exposure to Pulmonary Toxicants: Use of Biological Markers", Dallas, Texas, February, 1991

Presentation to Conference on Hormonal Carcinogenesis, "Issues on Risk Assessment", Cancun, Mexico, March, 1991.

Co-organizer, Dioxin 91 Conference, Research Triangle Park, September 1991. Presented conference summary on integration of biological data in risk assessment and paper on animal cancer.

Presentation to the American Cancer Society's Mary Lasker Conference on Molecular Epidemiology of Risk Assessment entitled, "Will Biomarkers Lead Us Out of the Wilderness," Sarasota, Florida, April 3-5, 1991.

Invited Seminars, Presentations, Symposia: (continued)

Presentation to the Eighth Health Effects Institute Annual Conference on, "Animal Models for Cancer and Human Risk: Potential Role of Biomarkers," Colorado Springs, Colorado, April 21-24, 1991.

Participant in IARC Workshop on Use of Data on Mechanisms of Carcinogenesis in Risk Identification. Prepared background paper on "Receptor-Mediated Carcinogenesis" and Chaired Working Group on Mechanisms. Lyon, France, June 11-18, 1991.

Speaker and Chairperson at IARC meeting on "Biomonitoring and Susceptibility Markers in Human Cancer: Applications in Molecular Epidemiology and Risk Assessment," Kailua-Kona, Hawaii, October 27 - November 2, 1991.

Presentation to Society of Risk Analysis Symposium on Dioxin Risk Assessment. Presentation entitled, "Relevance of Animal Data to Human Responses," Baltimore, Maryland, December 9, 1991.

Presentation to ILSI Seminar Series at the Brookings Institution entitled, "Dose-Response Relationships for Dioxin's Effects," Washington, D.C., March 19, 1992.

Presentation to Symposium on Incorporating Molecular Mechanisms into Estimates of Cancer Risk. Presentation entitled, "Dose-Response Relationships for Dioxin in a Rat Liver Tumor Promotion Model: Implications for Risk Assessment." University of Connecticut, Storrs, Connecticut, April 23-24, 1992.

Presentation to EPA Open Meeting on Reevaluation of Dioxin's Risks. Presentation entitled, "Dose-Response Models for Dioxin's Effects," Washington, D.C., April 28, 1992.

Plenary Presentation to Dioxin '92 Symposium, "Receptor-Mediated Responses and Dioxin Toxicity." Tampere, Finland, August 23-27, 1992.

Presentations to EPA Peer Review Panel for Reevaluation of Dioxin's Risks. Presentations entitled, "Carcinogenesis in Experimental Animals," and "Dose Response Models for Dioxin's Effects," Washington, D.C., September 22-24, 1992.

Seminar to Rutgers University and Robert Wood Johnson Medical School entitled, "Dose Response Relationships for Dioxin's Effects," Piscataway, New Jersey, October 22, 1992.

Presentation to US-Italy Symposium on Molecular Epidemiology. Presentation entitled, "Lab Studies of dioxin and Cancer Risks: Implications for Risk Assessment," Genoa, Italy, November 2-3, 1992.

Invited Seminars, Presentations, Symposia: (continued)

Seminar to University of Milan entitled, "The Ah Receptor and Dioxin: Human and Animal Data", Milan, Italy, November 6, 1992.

Presentation to Toxicology Forum on Current Views on the Impact of Dioxins and Furans on Human Health and the Environment. Presentation entitled, "Hormonal Influences on Tumor Induction," Berlin, Germany, November 9-11, 1992.

Presentation to Washington, D.C. Society of Toxicology Symposium. Presentation entitled, "Dose Response Relationships for Dioxin's Effects," Washington, D.C., December 3, 1992.

Presentation to Conference on Receptor-mediated Biological Processes: Implications for Evaluating Carcinogens. Presentation entitled, "Receptor-mediated Responses: Estrogens, Dioxins, and Interactions," Barton Creek, Texas, December 8-11, 1992.

Presentation to Society of Toxicology Symposium on Hormonal Carcinogenesis: Challenges for Future Research. Presentation entitled, "Receptor-mediated Carcinogenesis," New Orleans, Louisiana, March 14-18, 1993.

Presentation to Symposium on Human Tissue Monitoring and Specimen Banking. Presentation entitled, "Choice of Bankable Tissues for Evaluating Intra and Interindividual Variation," Research Triangle Park, North Carolina, March 30-31, 1993.

Presentation to International Congress on the Health Effects of Hazardous Wastes. Presentation entitled, "Molecular Epidemiologic Approaches to Assessing Public Health Impacts of Hazardous Wastes," Atlanta, Georgia, May 3-6, 1993.

Presentation to International Congress on the Health Effects of Hazardous Wastes. Presentation entitled, "Receptor Mechanisms and Risk Assessment," Atlanta, Georgia, May 3-6, 1993.

Presentation to International Congress on Toxic Combustion By-products. Presentation entitled, "Molecular Dosimetry of Environmental Carcinogens," Cambridge, Massachusetts, June 14-16, 1993.

Presentation to Gordon Research Conference on Hormonal Carcinogenesis. Presentation entitled, "Risk Assessment of Receptor-mediated Carcinogens," Salve Regina College, Newport Rhode Island, August 8-13, 1993.

Symposium on "Breast Cancer and the Environment: What We Know, What We don't Know, What We Need to Know," Chairman, Workgroup on Identification of Breast Carcinogens, Adelphi University, Garden City, New York, November 15-16, 1993.

Invited Seminars, Presentations, Symposia: (continued)

Presentation to AACR Conference on Risk Assessment in Environmental Carcinogens on "Receptor-Mediated Responses and Risk Assessment," Whistler, British Columbia, Canada, January 17-22, 1994.

Presentation to American Society of Preventive Oncology on "Gene/Environment Interactions," Bethesda, Maryland, March 7-9, 1994.

Presentation to Carcinogenesis Specialty Section of Society of Toxicology on "NTP Science and Policy Issues," Dallas, Texas, March 14-17, 1994.

Seminar to University of Cincinnati, Department of Environmental Health entitled, "Mechanism Based Toxicology and Risk Assessment," Cincinnati, Ohio, May 11, 1994.

Panel Member, Chlorine/Dioxin Plenary Session, Public Relations Society of America 1994 National Environmental Conference, Washington, D.C., June 20, 1994.

Co-Chair of Workshop on Risks and Benefits of Hormone Replacement Therapy and Oral Contraceptive Use, Stockholm, Sweden, July 1994.

Presentation to NIEHS Advisory Council on "Mechanism Based Toxicology and Risk Assessment," Research Triangle Park, NC, September 1994.

Presentation to North Carolina Supercomputing Center Symposium on Environmental Impact Prediction, "Comparison of National, State and Local Decision-Making and the Role of Simulation Technology," Research Triangle Park, NC, October 6, 1994.

Presentation to IARC Workshop on Receptor-Mediated Carcinogenesis: Receptor-Mediated Events and EPA's Reevaluation of Dioxin's Risks, Lyon France, October 14-16, 1994.

Presentation to American Public Health Association Symposium on Environmental Exposures Affecting the Health of Children: Problems and Solutions, Washington, D.C., November 1, 1994.

Presentation to North Carolina Society of Toxicology Entitled, "Recent Scientific Advances and Dioxin Risk Assessment," Chapel Hill, NC, November 1994.

Chair, Organizing Committee for NTP Workshop on Mechanism-Based Toxicology in Cancer Risk Assessment: Implications for Research, Regulation and Legislation. Presentation Entitled, "NTP in The Third Millennium." Chapel Hill, NC, January 11-13, 1995.

Invited Seminars, Presentations, Symposia: (continued)

Presentation to Toxicology Forum Entitled, "Mechanism-Based Toxicology and Risk Assessment," Washington, D.C., February 1995.

Organizer and Chair of Society of Toxicology Workshop on NTP Studies: Principles of Dose Selection and Applications to Mechanistic-Based Risk Assessment, Baltimore, MD, March 1995.

Presentation to Society of Toxicology Symposium on Cell Cycle Controls and Carcinogenesis. Baltimore, MD, March 1995.

Presentation to Society of Toxicology Symposium Entitled, "Debate on Risk Assessment for Receptor-Mediated Carcinogens," Baltimore, MD, March 1995.

Plenary Presentation to Symposium on Managing Occupational and Environmental Health Hazards, Helsinki, Finland, March 1995.

Chair, Organizing Committee for Workshop on Review of the Criteria and Listing in the Biennial Report on Carcinogens, Washington, D.C., April 1995.

Chair, Working Group on Research Needs for Dose Response Relationships. EPA Workshop on Endocrine Disrupters, Research Triangle Park, NC, April 1995.

Chair and Presenter in Session on "Biomarkers of Exposure," International Congress of Toxicology, Seattle, WA, July 1995.

Panelist on American Chemical Society Panel on "Changing Regulations, Chicago, IL, August 1995

Chair, Session on Hormonally-Active Chemicals at Gordon Research Conference on Hormonal Carcinogenesis, New Hampshire, August 1995.

Briefing to White House Staff on "Endocrine Disrupters, What We Know and What We Don't Know," Washington, D.C., September 1995.

Presentation to Dupont Chemical Company Entitled, "Mechanism-based Toxicology," Wilmington, DE, September 1995.

Presentation to Conference on Receptor-Mediated Toxicants and Their Risk Assessment, Entitled, "Confounding Factors for Endocrine Disrupters," Washington, D.C., October 1995.

Invited Seminars, Presentations, Symposia: (continued)

Presentation to Conference on Prevention of Environmentally-Related Cancer, Entitled, "Problems in Estimating Cancer Risks," Albuquerque, NM, October 1995.

Presentation to NIEHS Grantees in Worker Training, Entitled, "The NTP and Occupational Health," Research Triangle Park, NC, October 1995.

Presentation to Collegium Ramazzini Symposium on Living in a Chemical World, Entitled, "Molecular Toxicology and Risk Assessment," Washington, D.C., November 1995.

Plenary Presentation to NTP Workshop on Validation and Regulatory Acceptance of Alternative Toxicological Test Methods, Entitled, "The Role of the NTP in Test Method Development and Validation," Arlington, VA, December 1995.

Presentation to Meeting on Validation of Transgenic Animals in Toxicity Testing, Entitled, "Transgenic Animals and the NTP," Research Triangle Park, NC, February 1996.

Panelist on Implementation of EPA Revised Cancer Assessment Guidelines: Incorporation of Mechanistic and Pharmacokinetic Data, Society of Toxicology, Anaheim, CA, March 1996.

Chair, Session on Risk Assessment of Methylene Chloride, Society of Toxicology, Anaheim, CA, March 1996.

Presentation to Health Effects Institute Annual Meeting, Entitled, "Mechanism-based Toxicology and Risk Assessment: Use of Biomarkers," Ashville, NC, April 1996.

Plenary Presentation to Conference on Modulation of Chemical Toxicity and Risk Assessment, Entitled, "Dietary Factors and Risk Assessment Complexity", Tucson, AZ, June 1996.

Presentation to NTP Workshop on Developing Partnerships for the Validation of New Approaches for Toxicological Evaluations, Entitled, "New Initiatives for the NTP," Research Triangle Park, NC, July 1996.

Panelist on Society of Environmental Journalists Panel on Endocrine Disruptors, St. Louis, October 1996.

Presentation to Conference on Chemistry, Man and Environment, Entitled, "Use of Toxicology, Epidemiology, Toxicokinetics and Mechanisms in Risk Assessment of TCDD," Milan, Italy, October 1996.



Invited Seminars, Presentations, Symposia: (continued)

Presentation to Symposium on Dioxins and Furans: Epidemiologic Assessment of Cancer Risks and Other Human Health Effects, Entitled, "Molecular Epidemiology and Dosimetry of Dioxin and Related Chemicals," Heidelberg, Germany, November 1996.

Presentation to NIEHS Grantee Meeting On Endocrine Disruptors, Entitled, "Linking Fundamental Knowledge, Epidemiology, Toxicology and Risk Assessment: Good Science for Good Decisions," Research Triangle Park, NC, November 1996.

Presentation to BELLE Symposium on Toxicological Defense Mechanisms and the Shape of Dose Response Relationships, Entitled, "How Regulatory/Public Health Agencies Consider the Biological Effects of Low Level Exposures," Research Triangle Park, NC, November 1996.

Presentation to American College of Physicians, "Strengthening Science Base for Regulatory Decisions," NJ, January 1997.

Presentation to Society of Toxicology Workshop on the Use of Mode of Action Information in Cancer Risk Assessment, "Receptor Mediated Responses and Dioxin Cancer Risk," Cincinnati, OH, March 1997.

Presentation to EMF Science Review Symposium, "Risk Assessment: Salient Points and Steps for Consideration," Research Triangle Park, NC, March 1997.

Presentation to Environmental Management Commission, State of North Carolina, "Role of the Scientific Advisory Board in Risk Management," Raleigh, NC, April 1997.

Presentation to Workshop on Mechanistically-based Alternative Models for Toxicity Testing, "NTP Initiatives in Alternative Models," Research Triangle Park, NC, July 1997.

Chair of Organizing Committee for NIEHS Conference on Estrogens in the Environment.: Linking Fundamental Knowledge, Risk Assessment and Public Policy. Presentation Entitled, "Risk Assessment Issues: What We Know and Don't Know," Arlington, VA, July 1997.

Chair of Gordon Research Conference on Hormonal Carcinogenesis, Tilton, NH, July 1997.

Moderator, Session on Research Needs, Workshop on Marine Toxins, Research Triangle Park, NC, August 1997.

Invited Seminars, Presentations, Symposia: (continued)

Moderator, Workshop on Research Needs in Chemical Carcinogenesis, Conference on the Chemical Industries' Long-Range Research Initiatives, Research Triangle Park, NC, November 1997.

Chair of Organizing Committee for Workshop on Strategies for Assessing the Implications of Malformed Frogs for Environmental Health, Research Triangle Park, NC, December 1997.

Moderator, EPA Low Dose Workshop on Screening and Testing for Endocrine Disruptors, Washington, D.C., February 1998

Discussant, Conference on Superfund Communities: Who's Exposed and Who's at Risk, Session on Mechanistic Paradigms, Boston, MA, March 1998.

Internet Presentation, Talk City - Breakthroughs in Medicine, on Environmental Agents and Human Health, March 1998.

Presentation to Conference on Unique Freshwater Models for Environmental Health Research, "Uses of Aquatic Models by NIEHS and the NTP," Research Triangle Park, NC, April 1998.

Presentation to Science and Math Students at Northwood High School on "Rule of Science in Public Health Policy," Pittsboro, NC, April 1998.

Presentation to EPA Symposium on Extrapolation in Human Health and Ecological Risk Assessment, "Future Approaches for Improving Extrapolations to Health: Integration of Diverse Data Sets," Research Triangle Park, NC, April 1998.

Presentation to Workshop on Characterizing the Effects of Endocrine Disruptors on Human Health at Environmental Exposure Levels, "Quantitative Approaches to the Study of Homeostasis," Raleigh, NC, May 1998.

Presentation to Conference on Characterizing Human Risks, "The Changing Face of Toxicology: Mechanisms, Human Studies and Risk Assessment," Washington, D.C., May 1998.

Presentation to EPA Public Meeting on Drinking Water Disinfectant Byproducts, "Evaluation of New Science for Use in Chloroform Risk Assessments, Washington, D.C., May 1998.

Introductory Presentation to Peer-Review Panel on the Validation of the Local Lymph Node Assay for Use in Toxicology Testing, Gaithersburg, MD, September 1998.

Invited Seminars, Presentations, Symposia: (continued)

Introductory Presentation and Charge to Workshop to Evaluate Research Needs on the Use and Safety of Medicinal Herbs, Raleigh, NC, September 1998.

Introductory Presentation to Public Meeting on NIEHS Working Group Report on “Assessment of Health Effects from Exposure to Power-Line Frequency, Electric and Magnetic Fields, Washington, D.C., September 1998.

Presentation to Mississippi State University, “Critical Issues in Linking Science to Public Health Policy,” November 1998.

Presentation to Symposium Honoring David Rall entitled, “Can Rodent Cancer Tests Predict for Human Cancers: The Role of Mechanistic Studies in Cancer Testing,” Little Rock, AR, November 1998.

Chair of Organizing Committee for OSTP (White House) Workshop on Scientific Issues Relevant to Assessment of Health Effects from Exposure to Methylmercury, Raleigh, NC, November 1998.

Introductory Presentation to Peer Review Panel on Validation of Corrositex Assay for Use in Toxicology Testing, Bethesda, MD, January 1999.

Presentation at Society of Toxicology Meeting (Epidemiology Section) on the “Integration of Diverse Data Sets in Toxicological Evaluations,” New Orleans, LA, March 1999.

Presentation at Conference on Fumonisin Toxicity, “Developing Partnerships between FDA and NIEHS: Linking Science to Public Health Policy, Washington D.C., June 1999.

Presentation to NCI/NIEHS Joint Meeting on Environmental Health, “Opportunities for Collaborative Research,” Research Triangle Park, NC, June 1999.

Presentation to Workshop on Thimerosal Containing Vaccines, “Pharmacokinetics and Toxicity of Ethyl and Methylmercury,” Bethesda, MD, August 1999.

Moderator of EPA/NIEHS Workshop Roundtable on Applying Biomarker Research to Risk Assessment and Public Health, Chapel Hill, NC, August 1999.

Moderator (Research Recommendations Session) and Member of Steering Committee of Chemical Manufacturing Association Workshop to Evaluate Research Priorities for Endocrine Active Compound Risk Assessment Methods, Research Triangle Park, NC, August 1999.

Invited Seminars, Presentations, Symposia: (continued)

Presentation to Expert Panel Meeting on Reproductive Toxicity of Phthalate Esters (NTP Center for the Evaluation of Reproductive Risks), Washington, D.C., August 1999.

Chair, Session on Toxicokinetics at Dioxin 99 Meeting, Venice, Italy, September 1999.

Presentations, to NIEHS Council on "NTP Research Priorities and External Reviews" and "Medicinal Herb Research," Research Triangle Park, NC, September 1999.

Presentation to Stakeholder Public Meeting on the NTP's Report on Carcinogens, Washington, D.C., September 1999.

Co-Chair Organizing Committee and Moderator of Breakout Group Presentations for Workshop on "The Role of Human Exposure Assessment in the Prevention of Environmental Disease," Rockville, MD, September, 1999.

Member Organizing Committee, Workshop on the Harmonization of Cancer and Non-Cancer Risk Assessments, Washington, D.C., October, 1999.

Selected Advisory Boards and Related Activities:

Toxicology Forum; expert on developmental pharmacology for the purpose of protocol development for in vitro toxicity testing, 1978.

Environmental Protection Agency; implementation of Toxic Substances Act as it applies to children, 1981 - 1984.

Education program for nurses to increase their skills in environmental health, Health Resources Administration, 1981.

Member, Peer Review Panel, Food Chain Transport of Synfuels, Comparative Animal Research Laboratory, Oak Ridge, Tennessee.

Temporary Advisor to International Agency for Research on Cancer, "Mechanisms by which Hormones Influence Carcinogenesis," Lyon, France, April, 1983.

Consultant - Centers for Disease Control, Health Implications of TCDD Contamination of Residential Soil, June, 1983.

Consultant - U.S. Environmental Protection Agency, Risk Analysis of Synfuels, Corvallis, Oregon, October, 1983.

Selected Advisory Boards and Related Activities: (continued)

Peer Review Panel, National Center for Toxicological Research, Food and Drug Administration, Washington, D.C., November, 1984.

Organizing Committee, Section on Environmental Toxicology and Pharmacology, American Society for Pharmacology and Experimental Therapeutics, 1984 - 1987.

Chairman of Panel on "Application of Biochemical Markers in Risk Assessment", Committee to Coordinate Environmental Health and Related Programs, Department of Health and Human Services, 1986 - 1988.

National Institute of Environmental Health Sciences' Representative for NCI, NIOSH, EPA, NIEHS Extramural Program in Biochemical Epidemiology, 1986 - Date.

Member of Subcommittees of Research Needs and Risk Assessment, Committee to Coordinate Environmental Health and Related Programs, Department of Health and Human Services, 1986 - 1993.

EPA Scientific Advisory Board, Subcommittee on Halogenated Organics, September, 1986.

Office of Science and Technology Policy Panel on Risk Assessment, 1986.

International Program on Chemical Safety, Commission of the European Communities, WHO Committee to Prepare Consensus Report on "Biological Methods for Monitoring Exposure to Mutagenic or Carcinogenic Agents", July, 1987.

Member of the National Center for Toxicological Research Sponsored Panel on Reproductive Risk Assessment for Dioxin, Little Rock, Arkansas, September, 1987.

Scientific Advisory Board, PMI Strang Clinic, New York, 1987 - 1990.

Member of DHHS panel on "Evaluation of Risk Assessments of Dioxin", August, 1989.

Contributor to WHO/IPCS Monograph on Principles for the Assessment of Risk from Exposure to Chemicals. Prepared Background paper on Biological Markers of Exposure and Effect, 1989 - 1990.

Chairman, Dioxin Review Panel for Chemical Industry Institute of Toxicology, 1990 - 1992.

Member, Department of Health and Human Services Committee on Revision of Policies on Risk Assessment and Risk Management, 1990.

Selected Advisory Boards and Related Activities: (continued)

Member, Scientific Advisory Panel, Chemical Industry Institute of Toxicology, 1990.

Member, Subcommittee on Risk Assessment, DHHS Committee to Coordinate Environmental Health and Related Programs, 1990-1993.

Member, Working Party on Research Needs of the Committee on Life Sciences and Health Subcommittee on Risk Assessment, 1991.

Preparation of background paper on "Animal Cancer" for EPA's Reevaluation of Dioxin's Risks, 1991.

Co-chair Committee on "Dose-Response Model for Dioxin's Effects," for EPA's Reevaluation of Dioxin's Risks, 1992 - Date.

Health Effects Institute Panel on Research Needs for Mobile Air Emissions; chaired benzene working group, 1992 - 1993.

Chairman, Scientific Advisory Board for North Carolina Air Toxics Regulations, 1992 - Date.

Scientific Advisory Board, Chemical Industries Institute for Toxicology, 1993.

Organizing Committee, International Symposium on "Butadiene Health Effects," Helsinki, Finland, May 1993

IARC Workshop on Quantitative Estimation and Prediction of Cancer Risks to Humans, Lyon, France, October 18-22, 1993.

Vice Chair for Science, National Science and Technology Policy Subcommittee on Risk Assessment, 1994 - 1997.

Federal Liaison to EPA Science Advisory Board, Environmental Health Committee, 1994 - Date.

Co-Chair, Interagency Committee to Assess Health Effects of Oxygenated Fuels, 1995 - 1996.

Chair, National Occupational Research Agenda: Experimental Priorities, Washington, D.C., December 1995.

Selected Advisory Boards and Related Activities: (continued)

Congressional Testimony to House Science Committee, "Scientific Integrity, and Federal Policies and Mandates, December 1995.

Chair, Search Committee to Select Director for NIOSH Health Effects Laboratory Division, 1996.

Chair, IARC Monograph Meeting on Carcinogenicity of Tamoxifen and Other Pharmaceuticals, February 1996.

Presentation to National Research Council Committee on Research Opportunities and Priorities for EPA, May 1996.

Chair, National Science and Technology Interagency Review of EPA's Revised Guidelines for Reproductive and Developmental Toxicology, August 1996.

Steering Committee for Scientific Review of EPA's Methylene Chloride Risk Assessment - Co-Sponsored by EPA, NTP, ATSDR and the Halogenated Solvents Industrial Alliance, 1996 - Date.

Vice Chair for National Science and Technology Council Committee on Human Health Effects of Endocrine Disruptors, 1996 - Date.

Member, North Carolina Legislative Committee for Review of Air Toxics Programs in North Carolina, 1996 - 1997.

Member, Endocrine Disruptors Screening and Testing Advisory Committee (EDSTAC) for Addressing EPA's Congressional Mandates on Endocrine Disruptor Screens, 1996 - Date.

Member, Committee for Implementing NIOSH's National Occupational Research Agenda, 1996 - 1997.

Risk Characterization Writing Team for EPA's Reevaluation of Dioxin's Risk, 1996 - Date.

Chair, IARC Monograph Meeting on Carcinogenicity of Dioxin and Related Chemicals, February 1997.

Member, Technical Panel for World Trade Organization Adjudication of International Trade Dispute on Export of Animals Fed Growth Promoting Substances, February 1997.

Chair, Cancer White Paper Group, State of the Science Steering Committee, Chemical Manufacturing Association, 1997 - 1998.

Selected Advisory Boards and Related Activities: (continued)

Member, Endocrine Disruptor Steering Committee, Chemical Manufacturing Association, 1997 - Date.

Member, North Carolina Task Force on Human Health Effects of Pfiesteria Toxins, 1997 - 1998.

Member, Peer Review Panel for Review of Environmental Toxicology Program, NHEERL, EPA, 1997.

Member, Scientific Advisory Committee, Chemical Industries Institute for Toxicology, 1997 - 1998.

Chair, OSTP Coordinated Interagency Review of EPA's Report to Congress on Health Effects of Mercury, 1997 - Date.

Member, ILSI Risk Science Institute Steering Committee, Framework for Cumulative Risk Assessment, 1998 - 1999.

Member, WHO Steering Committee on Endocrine Disruptors, 1998 - Date.

Presentation on Research Priorities in Environmental Health to National Research Defense Council, June 1998.

Co-Chair, NC Department of Health Panel to Investigate Possible Health Effects of Intensive Livestock Farming, 1998 - Date.

Presentation to EPA Science Advisory Board for Integrated Exposure Assessment, "Exposure Assessment Issues for NIEHS and the NTP," March 1999.

Presentation to National Academy of Science Panel on Interagency Evaluations of Human Health Effects from Methylmercury Exposure, Washington, D.C., June 1999

Interagency Committee on Evaluation of European Union Risk Assessments on Health Effects of Consuming Meats from Growth-Promoted Animals, May 1999 - Date.

Science Advisory Board for Chemical Industries Institute for Toxicology, August 1999.

Co-Chair Committee on Environment and Natural Resources (White House Science Office) Review of NAS Report on Endocrine Disruptors, September 1999.



BIBLIOGRAPHY

1. Lucier, G. W. and Menzer, R. E.: Metabolism of dimethoate in plants in relation to its mode of application. *J. Agric. Food Chem.* 16: 936-945, 1968.
2. Lucier, G. W. and Menzer, R. E.: Nature of the oxidative metabolites of dimethoate formed in bean plants, rats and liver microsomes. *J. Agric. Food Chem.* 18: 698-704, 1970.
3. Brubaker, P. E., Lucier, G. W. and Klein, R.: The effects of methylmercury on protein synthesis in rat liver. *Biochem. Biophys. Res. Commun.* 44: 1552-1558, 1971.
4. Lucier, G. W., McDaniel, O. S. and Matthews, H. B.: Microsomal rat liver UDP-glucuronyltransferase: Effects of piperonyl butoxide and other factors on enzyme activity. *Arch. Biochem. Biophys.* 145: 520-530, 1971.
5. Lucier, G. W. and Menzer, R. E.: Nature of the neutral phosphorus ester metabolites of phosphamidon formed in rats and liver microsomes. *J. Agric. Food Chem.* 19: 1249-1255, 1971.
6. Matthews, H. B., McKinney, J. D. and Lucier, G. W.: Dieldrin metabolism excretion and storage in male and female rats. *J. Agric. Food Chem.* 19: 1244-1248, 1971.
7. Klein, R., Herman, S., Brubaker, P., Lucier, G. and Krigman, M. R.: A model of acute methylmercury intoxication in rats. *Arch. Pathol.* 93: 408-418, 1972.
8. Lucier, G. W., Klein, R., Matthews, H. B. and McDaniel, O. S.: Increased degradation of rat liver CO-binding particles by methylmercury hydroxide. *Life Sci. (Part II)* 11: 597-605, 1972.
9. Lucier, G. W. and McDaniel, O. S.: Alterations in rat liver microsomal and lysosomal b-glucuronidase by compounds which induce hepatic drug metabolizing enzymes. *Biochim. Biophys. Acta* 261: 168-176, 1972.
10. Lucier, G. W., McDaniel, O. S., Klein, R. and Brubaker, P. E.: Effects of methylmercury hydroxide on rat liver microsomal enzymes. *Chem. Biol. Interact.* 4: 265-280, 1972.
11. Lucier, G. W., McDaniel, O. S., Williams, C. and Klein, R.: Effects of chlordane and methylmercury on the metabolism of carbaryl and carbofuran in rats. *Pestic. Biochem. Physiol.* 2: 244-255, 1972.
12. Brubaker, P., Klein, R., Herman, S., Lucier, G., Alexander, L. and Long, M.: Methylmercury and protein synthesis: Cytogenetic disturbances in target organs of asymptomatic methylmercury-treated rats. *J. Mol. Pathol.* 18(3): 263-280, 1973.

13. Lucier, G. W., Matthews, H. B., Brubaker, P. E., Klein, R. and McDaniel, O. S.: Effects of methylmercury on microsomal mixed-function oxidase components of rodents. *Mol. Pharmacol.* 9: 237-246, 1973.
14. Lucier, G. W., McDaniel, O. S., Bend, J. R. and Faeder, E.: Effects of hycanthone and two of its chlorinated analogs on hepatic microsomes. *J. Pharmacol. Exp. Ther.* 186: 416-424, 1973.
15. Fowler, B. A., Brown, H. W., Lucier, G. W. and Beard, M. E.: Mercury uptake by renal lysosomes of rats ingesting methylmercury hydroxide: Ultrastructural observation and energy dispersive x-ray analysis. *Arch. Pathol.* 98: 297-301, 1974.
16. Fowler, B. A., Brown, H. W., Lucier, G. W. and Krigman, M. R.: The effects of chronic oral methylmercury exposure on the lysosome system of rat kidney. Morphometric and biochemical studies. *Lab. Invest.* 32: 313-322, 1975.
17. Fowler, B. A., Lucier, G. W. and Mushak, P.: Phenobarbital protection against methylmercury nephrotoxicity. *Proc. Soc. Exp. Biol. Med.* 149: 75-79, 1975.
18. Hook, G. E. R., Haseman, J. K. and Lucier, G. W.: Induction and suppression of hepatic and extrahepatic microsomal foreign compound metabolizing enzyme systems by 2,3,7,8-tetrachlorodibenzo-p-dioxin. *Chem. Biol. Interact.* 10: 199-214, 1975.
19. Hook, G. E. R., Orton, T. C., Moore, J. A. and Lucier, G. W.: 2,3,7,8-Tetrachlorodibenzo-p-dioxin induced changes in the hydroxylation of biphenyl by rat liver microsomes. *Biochem. Pharmacol.* 24: 335-340, 1975.
20. Lucier, G. W.: Microsomal glucuronidation of steroids using a rapid radiometric method. *J. Steroid Biochem.* 5: 681-687, 1974.
21. Lucier, G. W., McDaniel, O. S. and Hook, G. E. R.: Nature of the enhancement of hepatic UDP-glucuronyltransferase activity by 2,3,7,8-tetrachlorodibenzo-p-dioxin in rats. *Biochem. Pharmacol.* 24: 325-334, 1975.
22. Lucier, G. W., Sonowane, B. R., McDaniel, O. S. and Hook, G. E. R.: Postnatal stimulation of hepatic microsomal enzymes following administration of TCDD to pregnant rats. *Chem. Biol. Interact.* 11: 15-26, 1975.
23. Sonawane, B. R. and Lucier, G. W.: Hepatic and extrahepatic N-acetyltransferase: Perinatal development using a rapid radioassay. *Biochim. Biophys. Acta* 411: 97-105, 1975.

24. Goldstein, J. A., McKinney, J. D., Lucier, G. W., Hickman, P., Bergman, H. and Moore, J. A.: Toxicological assessments of hexachlorobiphenyl isomers and 2,3,7,8-tetrachlorodibenzofuran in chicks. *Toxicol. Appl. Pharmacol.* 36: 81-88, 1976.
25. Lee, I. P. and Lucier, G. W.: The potentiation of barbiturate-induced narcosis by procarbazine. *J. Pharmacol. Exp. Ther.* 196: 586-593, 1976.
26. Fowler, B. A., Hook, G. E. R. and Lucier, G. W.: Tetrachlorodibenzo-p-dioxin induction of renal microsomal enzyme systems: Ultrastructural effects on pars recta (S3) proximal tubule cells. *J. Pharmacol. Exp. Ther.* 20: 712-721, 1977.
27. Lucier, G. W., Sonowane, B. R. and McDaniel, O. S.: Glucuronidation and deglucuronidation reactions in hepatic and extrahepatic tissues during perinatal development. *Drug Metab. Dispos.* 5: 279-287, 1977.
28. Lucier, G. W. and McDaniel, O. S.: Steroid and non-steroid UDP-glucuronyltransferase: Glucuronidation of synthetic estrogens as steroids. *J. Steroid Biochem.* 8: 867-873, 1977.
29. Lamartiniere, C. A. and Lucier, G. W.: Fetal programming of hepatic histidase by diethylstilbestrol. *J. Steroid Biochem.* 9: 595-599, 1978.
30. Lucier, G. W., Schiller, C. M., McDaniel, O. S. and Matthews, H. B.: Structural requirements for the accumulation of PCB metabolites in the fetal intestine. *Drug Metab. Dispos.* 6: 584-590, 1978.
31. Powell-Jones, W., Nayfeh, S. N. and Lucier, G. W.: Translocation of 4S and 5S forms of estrogen receptors into rat liver nuclei. *Biochem. Biophys. Res. Commun.* 85(1): 167-173, 1978.
32. Schiller, C. M. and Lucier, G. W.: Differential susceptibility of intestinal crypt and tip cells to TCDD inductive actions. *Chem. Biol. Interact.* 22: 199-209, 1978.
33. Dieringer, C. S., Lamartiniere, C. A. and Lucier, G. W.: Sex differences in pituitary-gonadal regulation of 5 alpha-reductase and 16 alpha-hydroxylase. *J. Steroid Biochem.* 11: 1519-1525, 1979.
34. Dieringer, C. S., Lamartiniere, C. A., Schiller, C. M. and Lucier, G. W.: Altered ontogeny of hepatic steroid-metabolizing enzymes by pure PCB congeners. *Biochem. Pharmacol.* 28: 2511-2514, 1979.
35. Illsley, N. P., Lamartiniere, C. A. and Lucier, G. W.: Analysis of the sex specific changes in rat hepatic cytosol protein patterns using two dimensional gel electrophoresis. *J. Appl. Biochem.* 1: 385-395, 1979.

36. Lamartiniere, C. A., Dieringer, C. S. and Lucier, G. W.: Altered ontogeny of glutathione-S-transferase by 2,4,5,2',4'5'-hexachlorobiphenyl in rat liver. *Toxicol. Appl. Pharmacol.* 51: 233-238, 1979.
37. Lamartiniere, C. A., Dieringer, C. S. and Lucier, G. W.: Altered sexual differentiation of hepatic UDP-glucuronyltransferase by neonatal hormone treatment. *Biochem. J.* 180: 313-318, 1979.
38. Tilson, H. A., Davis, G. J., McLachlan, J. A. and Lucier, G. W.: Behavioral changes in mice by prenatal PCB exposure. *Environ. Res.* 18: 466-474, 1979.
39. Dieringer, C. S., Lamartiniere, C. A. and Lucier, G. W.: Neonatal treatment with diethylstilbestrol or testosterone alters sex differentiation of hepatic steroid-metabolizing enzymes. *J. Steroid Biochem.* 13: 1449-1453, 1980.
40. Lui, E. M. K. and Lucier, G. W.: Neonatal feminization of hepatic monooxygenase in adult male rats: Altered sexual dimorphic response to cadmium. *J. Pharmacol. Exp. Ther.* 212: 211-216, 1980.
41. Powell-Jones, W., Thompson, C. L., Nayfeh, S. N. and Lucier, G. W.: Sex differences in estrogen binding by cytosolic and nuclear components of rat liver. *J. Steroid Biochem.* 13: 219-229, 1980.
42. Schiller, C. M., Walden, R. and Lucier, G. W.: Enzyme development of the hamster small intestine: Distribution of shuttle enzymes. *Comp. Biochem. Physiol.* 650: 419-422, 1980.
43. Curley, W. H., Lucier, G. W. and Schiller, C. M.: Comparison of hepatic and intestinal  $\beta$ -glucuronidase from adult male Fischer rats. *Comp. Biochem. Physiol.* 68: 1-8, 1981.
44. Lui, E. M. K. and Lucier, G. W.: Feminization of rat liver monooxygenase by neonatal methadone treatment. *Pediatric Pharmacol.* 1(3): 187-196, 1981.
45. Lui, E. M. K. and Lucier, G. W.: Hypophyseal regulation of cadmium-induced depression of the hepatic monooxygenase system in the rat. *Mol. Pharmacol.* 20: 165-172, 1981.
46. Lucier, G. W., Slaughter, S. R., Thompson, C., Lamartiniere, C. A., and Powell-Jones, W.: Selective actions of growth hormone on rat liver estrogen binding proteins. *Biochem. Biophys. Res. Commun.* 103: 872-879, 1981.
47. Powell-Jones, W., Raeford, S. and Lucier, G. W.: Binding properties of zearalenone mycotoxins to hepatic estrogen receptors. *Mol. Pharmacol.* 20: 35-42, 1981.
48. Powell-Jones, W., Thompson, C., Raeford, S. and Lucier, G. W.: Ontogeny of estrogen-binding components in rat liver cytosol. *Endocrinology* 109: 628-637, 1981.

49. Thompson, C., Powell-Jones, W. and Lucier, G. W.: Sex differences in hepatic estrogen binding proteins. *Biochem. J.* 194: 1-8, 1981.
50. Lamartiniere, C. A., Luther, M. A., Lucier, G. W. and Illsley, N. P.: Altered imprinting of rat liver monamine oxidase by o,p'-DDT and methoxychlor. *Biochem. Pharmacol.* 31: 647-651, 1982.
51. Lui, E. M. K., Slaughter, S. R., Philpot, R. M. and Lucier, G. W.: Endocrine regulation of cadmium-sensitive cytochrome P-450 in rat liver. *Mol. Pharmacol.* 22: 705-802, 1982.
52. Walden, R., Lucier, G. W. and Schiller, C. M.: Effects of polychlorinated biphenyls on the development of serum and intestinal marker enzymes. *J. Toxicol. Environ. Health* 9: 1-12, 1982.
53. Rumbaugh, R. C., Clark, J. C., McDaniel, O. S. and Lucier, G. W.: Feminization of hepatic estrogen binding proteins by ectopic pituitary. *Endocrinology* 112: 1363-1370, 1983.
54. Sloop, T. C., Clark, J. C., Rumbaugh, R. C. and Lucier, G. W.: Imprinting of hepatic estrogen binding proteins by neonatal androgens. *Endocrinology*, 112: 1639-1646, 1983.
55. Sloop, T. C., Sherman, B., Fisher, S. and Lucier, G. W.: High affinity estrogen binding in cytosol of winter flounder liver. *Mount Desert Island Biological Laboratory Bulletin* 22: 64-67. 1983.
56. Thompson, C., Hudson, P. M. and Lucier, G. W.: Correlation of hepatic estrogen receptor concentration and estrogen-mediated elevation of very low density lipoproteins. *Endocrinology* 112: 1389-1397, 1983.
57. Thompson, C. and Lucier, G. W.: Hepatic estrogen responsiveness: possible mechanisms for sexual dimorphism. *Mol. Pharmacol.* 24: 69-76, 1983.
58. Liu, Y. Y., Thompson, C. L., Powell-Jones, W., McDaniel, O. S. and Lucier, G. W.: Cytosolic and nuclear estrogen receptors in the isolated perfused rat liver. *J. Pharmacol. Exp. Ther.* 229: 474-480, 1984.
59. McConnell, E. E., Lucier, G. W., Rumbaugh, R. C., Albro, P. W., Harvan, D. J., Hass, J. R. and Harris, M. W.: Dioxin in Soil: Bioavailability after ingestion by rats and guinea pigs. *Science* 223: 1077-1079, 1984.
60. Rumbaugh, R. C., McCoy, Z. and Lucier, G. W.: Correlation of hepatic cytosolic androgen binding proteins with androgen induction of hepatic microsomal N-demethylase in the rat. *J. Steroid Biochem.* 21: 243-252, 1984.

61. Sloop, T. C., Sherman, B. and Lucier, G. W.: Characterization of cytosolic steroid binding proteins in liver of winter flounder, *Pseudopleuronectes americanus*. Gen Comp. Endocrinology 55: 157-162, 1984.
62. Mistry, P., Lucier, G. W. and Fowler, B. A.: High affinity lead binding proteins in rat kidney cytosol. J. Pharmacol. Exp. Ther. 232: 462-469, 1985.
63. Mastri, C., Mistry, P. and Lucier, G. W.: In vivo oestrogenicity and binding characteristics of alpha-zearalanol (P-1496) to different classes of oestrogen binding proteins in rat liver. J. Steroid Biochem. 23: 279-289, 1985.
64. Lundgren, K. and Lucier, G. W.: Differential enhancement of sister-chromatid exchange frequencies by alpha-naphthoflavone in cultured lymphocytes from smokers and non-smokers. Mutation Research, 143: 131-135, 1985.
65. Mastri, C., Sloop, T. C. and Lucier, G. W.: Nuclear interactions of zearalanol-oestrogen receptor complexes in rat liver: A comparison with oestradiol-17 $\beta$ . J. Steroid Biochem. 24(2): 519-523, 1986.
66. Lucier, G. W., Rumbaugh, R. C., McCoy, Z., Hass, R., Harvan, D. and Albro, P.: Ingestion of soil contaminated with 2,3,7,8-tetrachlorodibenzo-p-dioxin (TCDD) alters hepatic function in rats. Fundament. Appl. Toxicol. 6: 364-371, 1986.
67. Wong, T. K., Sloop, T. and Lucier, G. W.: Non-detectable concentrations of human placental Ah receptors are associated with potent induction of microsomal BaP hydroxylase in individuals exposed to polychlorinated biphenyls, quaterphenyls and dibenzofurans. Toxicol. Appl. Pharmacol. 85: 60-68, 1986.
68. Lundgren, K., Thompson, C. L., Andries, M. and Lucier, G. W.: Dioxin treatment of rats results in increased in vitro induction of sister-chromatid exchanges by alpha-naphthoflavone: An animal model for human exposure to halogenated aromatics. Toxicol. Appl. Pharmacol. 85: 189-195, 1986.
69. Collman, G. W., Lundgren, K., Shore, D., Thompson, C. L. and Lucier, G. W.: Effects of alpha-naphthoflavone on levels of sister chromatid exchanges in lymphocytes from active and passive cigarette smokers: Dose response relationships. Cancer Res. 46: 6452-6455, 1986.
70. Campen, D. B., Sloop, T. C., Maronpot, R. R. and Lucier, G. W.: Continued development of hepatic gamma-glutamyltranspeptidase positive foci upon withdrawal of 17alpha-ethynylestradiol in diethylnitrosamine initiated rats. Cancer Res. 47: 2328-2333, 1987.

71. Sabourin, P. J., Chen, B. T., Lucier, G., Birnbaum, L. S., Fisher, E. and Henderson, R. F.: Effect of dose on the absorption and excretion of <sup>14</sup>C-benzene administered orally or by inhalation in rats and mice. *Toxicol. Appl. Pharmacol.* 87: 325-336, 1987.
72. Sloop, T. C. and Lucier, G. W.: Dose-dependent elevation of Ah receptor binding by TCDD in rat liver. *Toxicol. Appl. Pharmacol.* 88: 329-337, 1987.
73. Lundgren, K., Andries, M., Thompson, C. and Lucier, G. W.: Alpha-naphthoflavone metabolized by 2,3,7,8-tetrachlorodibenzo-p-dioxin induced rat liver microsomes is a potent clastogen in Chinese Hamster ovary cells. *Cancer Res.* 47: 3662-3666, 1987.
74. Lundgren, K., Collman, G. W., Wang-Wuu, S., Tiernan, T., Taylor, M., Thompson, C. L. and Lucier, G. W.: Cytogenetic and chemical detection of human exposure to polyhalogenated aromatic hydrocarbons. *Environ. and Mol. Mutagen.* 11(1): 1-11, 1988.
75. Lundgren, K., Robison, L. L. and Lucier, G. W.: Increased frequencies of alpha-naphthoflavone induced sister chromatid exchanges in long-term survivors of childhood acute lymphoblastic leukemia. *Cancer Letters*, 36: 213-219, 1987.
76. Sunahara, G. I., Nelson, K. G., Wong, T. K. and Lucier, G. W.: Decreased human birth weights after in utero exposure to PCBs and PCDFs are associated with placental EGF-stimulated receptor autophosphorylation capacity. *Mol. Pharmacol.* 32: 572-578, 1987.
77. Andries, M. A., Lucier, G. W., Lundgren, K. and Thompson, C. L.: Metabolic activation of alpha-naphthoflavone by 2,3,7,8-tetrachlorodibenzo-dioxin-induced rat liver microsomes. *Chemical-Biological Interactions* 67: 33-47, 1988.
78. Sabourin, P. J., Bechtold, W. E., Birnbaum, L. S., Lucier, G. W. and Henderson, R. F.: Difference in the metabolism of inhaled 3H-Benzene by F344/N rats and B6C3F1 mice. *Toxicol. Appl. Pharmacol.* 94(1): 128-140, 1988.
79. Wang, S-L., Lucier, G. W., Everson, R. B. and Shiverick, K. T.: Smoking-related alterations in epidermal growth factor and insulin receptors in human placenta. *Mol. Pharmacol.* 34: 269-271, 1988.
80. Graham, M. J., Lucier, G. W., Linko, P., Maronpot, R. R. and Goldstein, J.A.: Increases in cytochrome P-450 mediated 17 $\beta$ -estradiol 2-hydroxylase activity in rat liver microsomes after both acute administration and subchronic administration of 2,3,7,8-tetrachlorodibenzo-p-dioxin (TCDD) in a two-stage hepatocarcinogenesis model. *Carcinogenesis* 9: 1935- 1941, 1988.
81. Medinsky, M. A., Sabourin, P. J., Lucier, G., Birnbaum, L. S. and Henderson, R. F.: A physiological model for simulation of benzene metabolism by rats and mice. *Toxicol. Appl. Pharmacol.* 99: 193-206, 1989.

82. Sabourin, P. J., Bechtold, W. E., Griffith, W. C., Birnbaum, L. S., Lucier, G. W. and Henderson, R. F.: Effect of exposure concentration, exposure rate, and route of administration on metabolism of benzene by F344 rats and B6C3F<sub>1</sub> mice. *Toxicol. Appl. Pharmacol.* 99: 421-444, 1989.
83. Ryan, R. P., Sunahara, G. I., Lucier, G. W., Birnbaum, L. S. and Nelson, K. G.: Decreased ligand binding to the hepatic glucocorticoid and EGF receptors after 2,3,4,7,8-pentachlorodibenzofuran and 1,2,3,4,7,8-hexachlorodibenzofuran treatment of pregnant mice. *Biochem. Pharmacol.* 98: 454-464, 1989.
84. Sunahara, G. I., Lucier, G. W., McCoy, Z., Bresnick, E. H., Sanchez, E. R., and Nelson, K. G.: Characterization of 2,3,7,8-tetrachlorodibenzo-p-dioxin- mediated decreases in dexamethasone binding to rat hepatic cytosolic glucocorticoid receptor. *Mol. Pharmacol.* 36: 239-247, 1989.
85. Thompson, C. L., McCoy, Z., Lambert, J. M., Andries, M. J. and Lucier, G. W.: Relationships between benzo(a)pyrene metabolism, benzo(a)pyrene diol epoxide DNA adduct formation and sister chromatid exchanges in human lymphocytes from smokers and non-smokers. *Cancer Res.* 49: 6503-6511, 1989.
86. Vickers, A. E. M., Nelson, K., McCoy, Z. and Lucier, G. W.: Changes in estrogen receptor, DNA ploidy, and estrogen metabolism in hepatocytes during a two-stage model for hepatocarcinogenesis using 17 alpha-ethinylestradiol as the promoting agent. *Cancer Res.* 49: 6512-6520, 1989.
87. Jahnke, G. D., Thompson, C. L., Walker, M. P., Gallagher, J. E., Lucier, G. W. and DiAugustine, R. P.: Multiple DNA adducts in lymphocytes of smokers and nonsmokers determined by <sup>32</sup>P-postlabeling analysis. *Carcinogenesis* 11: 205-211, 1990.
88. Campen, D., Maronpot, R. and Lucier, G. W.: Dose response relationships in promotion of rat hepatocarcinogenesis by 17 alpha-ethinylestradiol. *J. Toxicol. Environ. Hlth.* 29: 257-268, 1990.
89. Andries, M. J., Lucier, G. W., Goldstein, J. and Thompson, C. L.: Involvement of cytochrome P-450C in alpha-naphthoflavone metabolism by rat liver microsomes. *Mol. Pharmacol.* 37(6): 990-995, 1990.
90. Sabourin, P. J., Sun, J. D., MacGregor, J. T., Wehr, C. M., Birnbaum, L. S., Lucier, G. W. and Henderson, R. F.: Effect of repeated benzene inhalation exposure on benzene metabolism, binding to hemoglobin and induction of micronuclei. *Toxicol. Appl. Pharmacol.* 103: 452-462, 1990.
91. Sun, J. D., Medinsky, M. A., Birnbaum, L. S., Lucier, G. and Henderson, R. F.: Benzene hemoglobin adducts in mice and rats: characterization of formation and physiological modeling. *Fundamental Appl. Toxicol.* 15: 468-475, 1990.



92. Dahl, A. R., Schlesinger, R. B., Heck, H., Medinsky, M. A. and Lucier, G. W.: Comparative dosimetry of inhaled material: differences among animal species and extrapolation to man. *Toxicol. Appl. Pharmacol.* 16: 1-13, 1991.
93. Lucier, G. W.: Humans are a sensitive species to some of the biochemical effects of TCDD and its structural analogs. *Environ. Tox. Chem.* 10: 727-735, 1991.
94. Vickers, A. E. M. and Lucier, G. W.: Estrogen receptor, epidermal growth factor receptor and cellular ploidy in elutriated subfractions of hepatocytes during liver tumor promotion by 17 alpha-ethinylestradiol in rats. *Carcinogenesis* 12:391-399, 1991.
95. Lin, F. H., Stohs, S. J., Birnbaum, L. S., Clark, G., Lucier, G. W. and Goldstein, J. A.: The effects of 2,3,7,8-tetrachlorodibenzo-p-dioxin (TCDD) on the hepatic estrogen and glucocorticoid receptors in congenic strains of Ah responsive and Ah nonresponsive C57BL/6J mice. *Toxicol. Appl. Pharmacol.* 108: 129-139, 1991.
96. Lin, F. H., Clark, G. Birnbaum, L. S., Lucier, G. W. and Goldstein, J. A.: The influence of the Ah locus on the effects of 2,3,7,8-tetrachlorodibenzo-p-dioxin on the hepatic epidermal growth factor receptor. *Mol. Pharmacol.* 39: 307-313, 1991.
97. Lucier, G. W., Tritscher, A., Goldsworthy, T., Foley, J., Clark, G., Goldstein, J. and Maronpot, R.: Ovarian hormones enhance TCDD-mediated increases in cell proliferation and preneoplastic foci in a two stage model for rat hepatocarcinogenesis. *Cancer Research* 51: 1391-1397, 1991.
98. Liu, Y. H., Taylor, J. A., Lucier, G.W. and Thompson, C.L.: Glutathione-s-transferase (GT) activity in human liver and lymphocytes and its role in regulating carcinogen-derived DNA adduct formation. *Carcinogenesis* 12 (12): 2269-2275, 1991.
99. Clark, G., Taylor, M. J., Tritscher, A. M., and Lucier, G. W.: Tumor necrosis factor involvement in 2,3,7,8-tetrachlorodibenzo-p-dioxin (TCDD) mediated hypersensitivity in C57Bl/6J mice congenic at the Ah locus. *Toxicol. Appl. Pharmacol.* 111: 422-431, 1991.
100. Randerath, E., Randerath, K., Reddy, R., and Lucier, G. W.: Sexual dimorphism of the chromatographic profiles of I-compounds (endogenous deoxyribonucleic acid modifications) in rat liver. *Endocrinology* 129: 3093-3100, 1991.
101. Greenlee, W. F., Andersen, M. E., and Lucier, G. W.: A perspective on biologically-based approaches to dioxin risk assessment. *J. Risk Analysis* 11: 565-568, 1991.
102. Bechtold, W. E., Medinsky, M. A., Lucier, G. W., Birnbaum, L. S., Yin, S. -N., Li, G. -L., and Henderson, R. F.: Muconic acid determinations in urine as a biological exposure index for workers occupationally exposed to benzene. *American Ind-Hyg. Assoc. J.* 52 (11): 473-478, 1991.

103. Bechtold, W. E., Sun, J. D., Birnbaum, L. S., Yin, S. N., Li, G. L., Kasicki, S., Lucier, G., and Henderson, R. F.: S-Phenylcysteine formation in hemoglobin as a biological exposure index to benzene. *Arch. Toxicol.* 66: 303-309, 1992.
104. Johnson, E. S., and Lucier, G. W.: Perspectives on risk assessment impact of recent reports on benzene. *Am. J. Indust. Med.* 21: 749-757, 1992.
105. Tritscher, A. M., Goldstein, J. A., Portier, C. J., McCoy, Z., Clark, G. C., and Lucier, G. W.: Dose-response relationships for chronic exposure to 2,3,7,8-Tetrachlorodibenzo-p-dioxin in a rat tumor promotion model: quantification and immunolocalization of CYP1A1 and CYP1A2 in the liver. *Cancer Res.* 52: 3436-3442, 1992.
106. Sabourin, P. J., Muggenburg, B. A., Couch, R. C., Lefler, D., Lucier, G., Birnbaum, L. S., and Henderson, R. F.: Metabolism of [<sup>14</sup>C]Benzene by Cynomolgus Monkeys and Chimpanzees. *Toxicol. Appl. Pharmacol.* 114: 277-284, 1992.
107. Taylor, M. J., Lucier, G. W., Mahler, J. F., Thompson, M., Lockhart, A. C., and Clark, G. C.: Inhibition of TCDD toxicity by treatment with anti-tumor necrosis factor antibody or dexamethasone. *Toxicol. Appl. Pharmacol.* 117: 126-132, 1992.
108. Walker, M. P., Jahnke, G. D., Snedeker, S. M., Gladen, B. C., Lucier, G. W., and DiAugustine, R. P.: <sup>32</sup>P-Postlabeling analysis of the formation and persistence of DNA adducts in mammary glands of parous and nulliparous mice treated with benzo[a]pyrene. *Carcinogenesis* 98: 2009-2015, 1992.
109. Portier, C., Tritscher, A., Kohn, M., Sewall, C., Clark, G., Edler, L., Hoel, D., and Lucier, G.: Ligand/receptor binding for 2,3,7,8-TCDD: implications for risk assessment. *Fundamental Appl. Toxicol.* 20: 48-56, 1993.
110. Kohn, M. C., Lucier, G. W., and Portier, C. J.: A mechanistic model of effects of dioxin on gene expression in the rat liver. *Toxicol. Appl. Pharmacol.* 120: 138-154, 1993.
111. Maronpot, R. R., Foley, J. F., Takahashi, K., Goldsworthy, T., Clark, G., Tritscher, A., Portier, C., and Lucier, G.: Dose response for TCDD promotion of hepatocarcinogenesis in rats initiated with DEN: Histologic, biochemical, and cell proliferation endpoints. *Environ. Hlth. Perspect.* 101(7): 634-643, 1993.
112. Bell, D. A., Taylor, J. A., Paulson, D. F., Robertson, C. N., Mohler, J. L., and Lucier, G. W.: Genetic risk and carcinogen exposure: a common inherited defect of the carcinogen-metabolism gene glutathione S-transferase M1 (GSTM1) that increases susceptibility to bladder cancer. *J. Natl. Cancer Inst.* 85 (14): 1159-1164, 1993.

113. Sewall, C. H., Lucier, G. W., Tritscher, A. M., Clark, G. C.: TCDD-Mediated changes in hepatic epidermal growth factor receptor may be a critical event in the hepatocarcinogenic action of TCDD. *Carcinogenesis* 14 (9): 1885-1893, 1993.
114. Bell, D. A., Taylor, J. A., Butler, M. A., Stephens, E. Wiest, J., Brubaker, L. H., Kadlubar, F. F., and Lucier, G. W.: Genotype/phenotype discordance for human arylamine N-acetyltransferase (NAT2) reveals a new slow-acetylator allele common in African-Americans. *Carcinogenesis* 14 (8): 1689-1692, 1993.
115. Vanden Heuvel, J. P., Clark, G. C., Thompson, C. L., McCoy, Z., Miller, C. R., Lucier, G. W., and Bell, D. A.: CYP1A1 mRNA levels as a human exposure biomarker: The use of quantitative polymerase chain reaction to measure CYP1A1 expression in peripheral blood lymphocytes. *Carcinogenesis* 14: 2003-2006, 1993.
116. Stephens, E. A., Taylor, J. A., Kaplan, N., Yang, C-H., Hsieh, L. L., Lucier, G. W., and Bell, D. A.: Ethnic variation in the CYP2E1 gene: Polymorphism Analysis of 695 African- Americans, European-Americans and Taiwanese Indicates the Presence of a Unique Haplotype in Taiwanese. *Pharmacogenetics* 4 (4): 185-192, 1994 .
117. Vanden Heuvel, J. P., Clark, G. C., Tritscher, A. M., Greenlee, W. F., Lucier, G. W., and Bell, D. A.: Dioxin-responsive genes: examination of dose-response relationships using quantitative reverse transcriptase-polymerase chain reaction. *Cancer Res.* 54: 62-68, 1994.
118. Vanden Heuvel, J. P., Clark, G. C., Tritscher, A. M., and Lucier, G. W.: Accumulation of polychlorinated dibenzodioxins and dibenzofurans in liver of control laboratory rats. *Fund. Appl. Toxicol.* 23: 465-469, 1994.
119. Kohn, M. C., Lucier, G. W., and Portier, C. J.: The importance of biological realism in dioxin risk assessment models. *Risk Analysis*, 14 (6): 993-1000, 1994.
120. Yager, J. D., Zurlo, J., Sewall, C. H., Lucier, G. W., and He, H.: Growth stimulation followed by growth inhibition in livers of female rats treated with ethinyl estradiol. *Carcinogenesis* 15 (10): 2117-2123, 1994.
121. Gallagher, J., Everson, R., George, M., and Lucier, G.: Comparison of DNA adduct levels in human placenta from polychlorinated biphenyl exposed women and smokers in which CYP 1A1 levels are similarly elevated. *Teratogenesis, Carcinogenesis and Mutagenesis* 14: 183-192, 1994.
122. Landi, M. T., Bertazzi, P. A., Shields, P. G., Clark, G., Lucier, G. W., Garte, S. J., Cosma, G., and Caporaso, N. E.: Association between CYP1A1 genotype, mRNA expression and enzymatic activity in humans. *Pharmacogenetics* 4: 242-246, 1994.

123. Walker, N. J., Gastel, J. A., Costa, L. T., Clark, G. C., Lucier, G. W., and Sutter, T. R.: Cytochrome P450 CYP1B1: Tissue-specific expression in sprague-dawley rats treated with 2,3,7,8-tetrachlorodibenzo-p-dioxin. *Carcinogenesis* 16: 1319-1327, 1995.
124. Sewall, C. H., Flagler, N., Vanden Heuvel, J. P., Clark, G. C., Tritscher, A. M., Maronpot, R. M., and Lucier, G. W.: Alterations in thyroid function in female sprague-dawley rats following chronic treatment with 2,3,7,8-tetrachlorodibenzo-p-dioxin. *Toxicol. Appl. Pharmacol.* 132: 237-244, 1995.
125. Sewall, C. H., Clark, G. C., and Lucier, G. W.: TCDD reduces rat hepatic epidermal growth factor receptor: Comparison of binding, immunodetection, and autophosphorylation. *Toxicol. Appl. Pharmacol.* 132: 263-272, 1995.
126. Tritscher, A. M., Clark, G. C., Sewall, C., Sills, R. C., Maronpot, R., and Lucier, G. W.: Persistence of TCDD-induced hepatic cell proliferation and growth of enzyme altered foci after chronic exposure followed by cessation of treatment in DEN initiated female rats. *Carcinogenesis* 16 (11): 2807-2811, 1995.
127. Sewall, C. H., and Lucier, G. W.: Receptor-mediated events and EPA's reevaluation of dioxin risks. In: *Receptor Mediated Mechanisms and Carcinogenesis*. *Mutation Research* 333 (1-2): 111-122, 1995.
128. Kohn, M. C., Sewall, C. H., Lucier, G. W., and Portier, C. J.: A mechanistic model of effects of dioxin on thyroid hormones in the rat. *Toxicol. Appl. Pharmacol.* 136: 29-48, 1996.
129. Tritscher, A. M., Seacat, A. M., Yager, J. D., Groopman, J. D., Miller, B. D., Bell, D., Sutter, T. R., and Lucier, G. W.: Increased oxidative DNA damage in livers of TCDD treated intact but not ovariectomized rats. *Cancer Letters* 98: 219-225, 1996.
130. Bucher, J. R., Portier, C. J., Goodman, J. I., Faustman, E. M., and Lucier, G. W.: National Toxicology Program studies: Principles of dose selection and applications to mechanistic based risk assessment. *Fund. Appl. Toxicol.* 31: 1-8, 1996.
131. Portier, C. J., Sherman, C. D., Kohn, M., Edler, L., Kopp-Schneider, A., Maronpot, R. M., and Lucier, G.: Modeling the number and size of hepatic focal lesions following exposure to 2,3,7,8-TCDD. *Toxicol. Appl. Pharmacol.* 138: 20-30, 1996.
132. Vickers, A. E. M., and Lucier, G. W.: Estrogen receptor levels and occupancy in hepatic sinusoidal endothelial and kupffer cells are enhanced by liver tumor promotion induced by 17-alpha ethinylestradiol in rats. *Carcinogenesis* 17: 1235-1242, 1996.
133. Tuomisto, J., Sewall, C. H., Unkila, M., Pohjanvirta, R., Clark, G. C., Viluksela, M., Rozman, K., and Lucier, G. W.: Differences in binding of epidermal growth factor to liver

- membranes of TCDD-resistant and TCDD-sensitive rats after a single dose of TCDD. *Environ. Toxicol. Pharmacol.* 1: 109-116, 1996.
134. Sewall, C. H., Lucier, G. W., Earp, H. S., and Clark, G. C.: Regulation of rat liver epithelial cell growth and epidermal growth factor receptor by TCDD. *Carcinogenesis* (In Press), 1997.
  135. Selmin, O., Lucier, G. W., Clark, G. C., Tritscher, A. M., Vanden Heuvel, J. P., Gastel, J. A., Sutter, T. R., and Bell, D. A.: Isolation and characterization of a novel gene induced by 2,3,7,8-tetrachlorodibenzo-p-dioxin in rat liver. *Carcinogenesis* 17: 2609-2615, 1997.
  136. Landi, M. T., Consonni, D., Patterson Jr., D. G., Needham, L. L., Lucier, G., Brambilla, P., Gerthoux, P., Mocarrelli, P., Pesatori, A. C., Bertazzi, P. A., and Caporaso, N.: Elevated TCDD levels in females, 20 years after an industrial accident in Seveso. *Lancet* 349: 1811, 1997.
  137. Longnecker, M. P., Rogan, W. J., and Lucier, G. W.: The human health effects of DDT and PCBs and an overview of organochlorines in public health. *Ann. Rev. Public Health* 18: 211-244, 1997.
  138. Walker, N. J., Tritscher, A. M., Sills, R. C., Foley, J., and Lucier, G. W.: Hepatocarcinogenesis in a Sprague-Dawley rat initiation/promotion model following discontinuous exposure to TCDD. *Organohalogen Compounds* 34: 150-153, 1997.
  139. Masten, S. A., Grassman, J. A., Yang, X., Miller, C. R., Spencer, D. L., Lanier, K. M., Walker, N. J., Jung, D., Konietzko, J., Edler, L., Patterson, D. G., Jr., Needham, L. L., and Lucier, G. W.: Mechanistically based markers of exposure and response to dioxin in occupationally exposed individuals. *Organohalogen Compounds* 34: 80-85, 1997.
  140. van Birgelen, A. P. J. M., DeVito, M. J., Orzech, D., Walker, N., Birnbaum, L. S., Bucher, J., and Lucier, G.: Design of 2-year bioassays with dioxin-like compounds in female Sprague Dawley rats. *Organohalogen Compounds* 34: 154-159, 1997.
  141. Walker, N. J., Crofts, F. G., Li, Y., Lax, S. F., Hayes, C. L., Strickland, P. T., Lucier, G. W., and Sutter, T. R.: Induction and localization of cytochrome P450 1B1 (CYP1B1) protein in the livers of TCDD-treated rats: detection using polyclonal antibodies raised to histidine-tagged fusion proteins produced and purified from bacteria. *Carcinogenesis* 19 (3): 395-402, 1998.
  142. Walker, N. J., Miller, B. D., Kohn, M. C., Lucier, G. W., and Tritscher, A. M.: Differences in kinetics of induction and reversibility of TCDD-induced changes in cell proliferation and CYP1A1 expression in female Sprague-Dawley rat liver. *Carcinogenesis* 19 (8): 1427-1435, 1998.

143. Masten, S. A., Grassman, J. A., Miller, C. R., Spencer, D. L., Walker, N. J., Jung, D., Konietzko, J., Edler, L., Patterson, D. G., Jr., Needham, L. L., and Lucier, G. W.: Population-based studies of dioxin responsiveness: individual variation in CYP1A1 levels and relationship to dioxin body burden. *Organohalogen Compounds* 38: 13-16, 1998.
144. Walker, N. J., Tritscher, A. M., Sutter, T. R., and Lucier, G. W.: CYP1B1 and CYP1A1 exhibit differential dose-response relationships in the TCDD-treated female Sprague-Dawley rat liver. *Organohalogen Compounds* 34: 10-14, 1997.
145. Walker, N., Wyde, M., and Lucier, G.: Role of estrogen in the mechanism of hepatocarcinogenesis induced by TCDD in female rat liver. *Organohalogen Compounds* 37: 71-74.
146. Kim, A. H., Lucier, G. W., Tritscher, A. M., and Walker, N. J.: The use of tissue burden as a dose metric for TCDD-inducible responses is endpoint-specific. *Organohalogen Compounds* 37: 337-340, 1998.
147. Walker, N. J., Portier, C. J., Lax, S. F., Crofts, F. G., Li, Y., Lucier, G. W., and Sutter, T. R.: Characterization of the dose-response of CYP1B1, CYP1A1 and CYP1A2 in the liver of female Sprague-Dawley rats following chronic exposure to 2,3,7,8-tetrachlorodibenzo-p-dioxin. *Toxicol. Appl. Pharmacol.* 154: 279-286, 1999.
148. Spencer, D. L., Masten, S. A., Lanier, K. M., Yang, X., Grassman, J. A., Miller, C. R., Sutter, T. R., Lucier, G. W., and Walker, N. J.: Quantitative analysis of constitutive and 2,3,7,8-TCDD-induced CYP1B1 expression in human lymphocytes. *Cancer, Epidemiology, Biomarkers and Prevention* 8: 139-146, 1999.
149. Burkart, J. G., Helgen, J. C., Fort, D. J., Hoppe, D., Gallagher, K., Bowers, D., Propst, T. L., Gernes, M., Magner, J., Shelby, M., and Lucier, G.: Induction of *Xenopus Laevis* embryo mortality and malformation by water sources associated with field *Rana* deformities. *Environ. Health Perspect.* 106(12): 841-848, 1998.
150. Kari, F. W., Abdo, K., Haseman, J., Rao, G., Bucher, J., and Lucier, G.: Commentary on the advisability of using dietary restriction in chemical hazard identification studies. *Environ. Health Perspect.* (In Press), 1999.
151. Barr, D. B., Barr, J. R., Bailey, S. L., Lapeza Jr., C. R., Beeson, M. D., Caudill, S. P., Maggio, V. L., Schechter, A., Masten, S. A., Lucier, G. W., Needham, L. L., and Sampson, E. J.: Levels of methyleugenol in selected adults in the general U.S. population as determined by high resolution mass spectrometry. *Environ. Health Perspect.* (In Press), 1999.
152. Portier, C. J., Edler, L., Jung, D., Needham, L., Masten, S., Parham, F., and Lucier, G.: Half-lives and body burdens for dioxin and dioxin-like compounds in humans estimated from an occupational cohort in Germany. *Organohalogen Compounds* (In Press), 1999.

Journal Articles Submitted for Publication

1. Walker, N. J., Tritscher, A. M., Sills, R. C., Lucier, G. W., and Portier, C. J.: Hepatocarcinogenesis in female Sprague-Dawley rats following discontinuous treatment with 2,3,7,8-tetrachlorodibenzo-p-dioxin. *Toxicol. Sci.* 1999.
2. Tritscher, A. M., Mahler, J., Portier, C. J., Lucier, G. W., and Walker, N. J.: Induction of lung lesions in female rats following chronic oral exposure to 2,3,7,8-tetrachlorodibenzo-p-dioxin. *Carcinogenesis* 1999.
3. Wyde, M. E., Seely, J., Lucier, G. W., and Walker, N. J.: Toxicity of 2,3,7,8-tetrachlorodibenzo-p-dioxin in ovariectomized female Sprague-Dawley rats implanted with subcutaneous 17beta-estradiol pellets. *Toxicol. Sci.* 1999.
4. Wyde, M. E., Eldridge, S. A., Lucier, G. W., and Walker, N. J.: Influence of ovarian hormones and 17  $\beta$ -estradiol on altered hepatic foci development and cell proliferation induced by 2,3,7,8-tetrachlorodibenzo-p-dioxin. *Carcinogenesis* 1999.

BOOK CHAPTERS, CONFERENCE PROCEEDINGS, MONOGRAPHS

1. Lucier, G. W., McDaniel, O. S., Hook, G. E. R., Fowler, B. A., Sonawane, B. R., and Faeder, E.: TCDD-induced changes in rat liver microsomal enzymes. *Environ. Hlth. Perspect.* 5: 199-210, September, 1973.
2. Fowler, B. A., Lucier, G. W., Brown, H., and McDaniel, O. S.: Ultrastructural changes in rat liver cells following a single oral dose of TCDD. *Environ. Hlth. Perspect.* 5: 141-148, September, 1973.
3. Lucier, G. W., and Hook, G. E. R.: EHP: History and objectives. *Environ. Hlth. Perspect.* 8: 1-3, August, 1974.
4. Hastings, F., Lucier, G., and Klein, R.: Methylmercury-cholinesterase interactions in rats. *Environ. Health Perspec.* 12: 127-130, December, 1975.
5. Sonawane, B. R., Nordberg, M., Nordberg, G. F., and Lucier, G. W.: Placental transfer of <sup>109</sup>Cd in rats in relation to dose and gestation age. *Environ. Health Perspec.* 12: 97-103, December, 1975.
6. Lucier, G. W., Lee, I. P., and Dixon, R. L.: Effects of environmental agents on male reproduction. *In*: *The Testis*. Johnson, A. D., and Gomes, W. R. (Eds.): Academic Press, Vol. IV., pp. 578-598, 1977.
7. Lucier, G. W.: Perinatal development of conjugative enzymes. *Environ. Health Perspec.* 18: 25-34, 1977.
8. Lucier, G. W., Davis, J. G., and McLachlan, J. A.: Transplacental toxicity of PCBs and PBBs: Methodological approach. 17th Hanford Biology Symposium--Developmental Toxicology of Energy-Related Pollutants. Technical Information Center, Department of Energy, 188-204, 1978.
9. Lucier, G. W.: Pharmacological and toxicological significance of UDP-glucuronyltransferase during development. *In*: *Conjugation Reactions in Drug Biotransformation*. Aito, A. (Ed.): Elsevier Press, pp. 167-178, 1978.
10. Lucier, G. W., and McDaniel, O. S.: Developmental toxicology of the organohalogenes, effects on enzyme development. *Ann. N. Y. Acad. Sci.* 320: 449-457, 1979.
11. Lucier, G. W., Lamartiniere, C. A., Dieringer, C. A., and Lui, E.: Metabolic activation/deactivation during development. *Environ. Hlth. Perspect.* 29: 17-26, 1979.
12. Fowler, B. A., Hayes, A. W., and Lucier, G. W.: Organelles as tools in toxicology. *In*: *Modern Toxicology*. Hayes, W. (Ed.): Raven Press, New York, pp. 639-658, 1982.



13. Lucier, G. W.: Developmental aspects of drug conjugation. In: Developmental Toxicology. Kimmel, C., and Buelke-Sam, J. (Eds.): Raven Press, New York, pp. 101-114, 1981.
14. Lucier, G., Lui, E., and Powell-Jones, W.: Regulation of hepatic enzyme development by steroids. In: Environmental Factors in Human Growth and Development, Banbury Report 11, pp. 137-150, 1982.
15. Lamartiniere, C. A., Sloop, T., Clark, J., Tilson, H. A., and Lucier, G. W.: Organizational effects of hormones and hormonally-active xenobiotics on postnatal development. 12th Conference on Environmental Toxicology, USAF A FAMRL-TR-81-149, pp. 96-121, 1982.
16. Lucier, G. W., and Rumbaugh, R. C.: Endocrine host factors affecting experimental carcinogenesis. In: Modulators of Experimental Carcinogenesis. International Agency for Research on Cancer. Turusov, V., and Montesano, R. (Eds.), IARC Scientific Publications No. 51, Lyon, pp. 49-64, 1983.
17. Lucier, G. W., Rumbaugh, R. C., Sloop, T. C., and Thompson, C. L.: Sex differentiation of liver protein synthesis. In: Prevention of Physical and Mental Congenital Defects. Marois, M. (Ed.) Vol. 163C, Alan Liss Inc., New York, pp. 381-387, 1984.
18. Lucier, G. W., Thompson, C. L., Sloop, T. C., and Rumbaugh, R. C.: Sexual differentiation of rat hepatic estrogen and androgen action. In: Sexual Differentiation, Basic and Clinical Aspects. Serio, M., Zanisi, M., Motta, M., and Martini, L. (Eds.): Senono Symposia Publications from Raven Press, New York, p. 209-223, 1984.
19. Vickers, A. E. M., Sloop, T. C., and Lucier, G. W.: Mechanism of action of toxic halogenated aromatics. Environ. Hlth. Perspect., Vol. 59, p. 121-128, 1984.
20. Mastro, C., and Lucier, G. W.: Actions of hormonally-active chemicals in the liver. In: Toxicology of Endocrine System. Thomas, J., McLachlan, J., and Korach, K. (Eds.). Raven Press p. 335-357, 1985.
21. Lucier, G. W., Sloop, T. C. and Thompson, C. L.: Imprinting of hepatic estrogen action. In: Estrogens and the Environment. McLachlan, J.A. (Ed.) Elsevier Press, New York, p. 190-202, 1985.
22. Lucier, G. W., and Thompson, C. L.: Issues in Biochemical Applications to Risk Assessment: When can lymphocytes be used as surrogate markers. Environ. Health Perspect. 76: 187-191, 1987.
23. Lucier, G. W., Nelson, K. G., Everson, R. B., Wong, T. K., Philpot, R. M., Tiernan, T., Taylor, M., and Sunahara, G. I.: Placental markers of human exposure to polychlorinated biphenyls and polychlorinated dibenzofurans. Environ. Health Perspect. 76: 79-87, 1987.

24. Nelson, K., Vickers, A., Sunahara, G., and Lucier, G. W.: Receptor and DNA ploidy changes during promotion of rat liver carcinogenesis. *In: Tumor Promoters: Biological Approaches for Mechanistic Studies and Assay Systems*, Barrett, J.C., Langenbach, R., and Elmore, E. (Eds.), Raven Press, New York, p. 387-405, 1988.
25. Goldstein, J. A., Graham, M. J., Sloop, T., Maronpot, R., Goodrow, T., and Lucier, G. W.: Effects of 2,3,7,8-tetrachlorodibenzo-p-dioxin (TCDD) on enzyme-altered foci, hepatocellular tumors, and estradiol metabolism in a two-stage hepatocarcinogenesis model. *Chemosphere*. 18(1-6): 695-700, 1989.
26. Thompson, C., Andries, M., Lundgren, K., Goldstein, J., Collman, G., and Lucier, G.: Humans exposed to polychlorinated biphenyls (PCBs) and polychlorinated dibenzofurans (PCDFs) exhibit increased SCE frequencies in lymphocytes when incubated with a-naphthoflavone: involvement of metabolic activation by P-450 isozymes. *Chemosphere*. 18(1-6): 687-694, 1989.
27. Nelson, K. G., Sunahara, G. I., Ryan, R., and Lucier, G. W.: TCDD-mediated decrease in dexamethasone binding to the hepatic glucocorticoid receptor is not accompanied by a decrease in immunodetectable glucocorticoid receptor protein concentrations: the role of adrenal steroids. *Chemosphere*. 18(1-6): 737-744, 1989.
28. Henderson, R. F., Sabourin, P. J., Bechtold, W. E., Griffith, W. C., Medinsky, M. A., Birnbaum, L. S., and Lucier, G. W.: The effect of dose, dose rate, route of administration and species on tissue and blood levels of benzene metabolites. *Environ. Health Perspect.* 82: 9-18, 1989.
29. Medinsky, M. A., Sabourin, P. J., Henderson, R. F., Lucier, G., and Birnbaum, L. S.: Differences in the pathways for metabolism of benzene in rats and mice simulated by a physiological model. *Environ. Health Perspect.* 82: 43-50, 1989.
30. Goldring, J. M., and Lucier, G. W.: Protein and DNA adducts. *In: Biological Markers in Epidemiology*. Hulka, B. (Ed.), Oxford University Press, New York, p. 78-104, 1989.
31. Lucier, G. W., Belinsky, S., and Thompson, C.: Molecular dosimetry of chemical carcinogens: Implications for epidemiology and risk assessment. *In: Proceedings from Assessment of Inhalation Hazards Integration and Extrapolation Using Diverse Data*. Mohr, U. (Ed.), Springer-Verlag p. 85-101, 1989.
32. Goldstein, J. A., Lin, F.-H., Stohs, S. J., Graham, M., Clark, G., Birnbaum, L., and Lucier, G.: The effects of 2,3,7,8-tetrachlorodibenzo-p-dioxin on epidermal growth factor receptor, glucocorticoid receptor and estrogen receptors in Ah responsive and nonresponsive congenic mice and the effects of TCDD on estradiol metabolism in a liver tumor promotion model in female rats. *In: Mouse Liver Carcinogenesis: Mechanisms and*

- Species Comparisons. Stevenson, D. E., McClain, M., Popp, J., Ward, J., Slaga, T., and Pitot, H. (Eds.), Alan Liss, New York, pp. 187-202, 1990.
33. Lucier, G. W., Sunahara, G. I., and Wong, T. K.: Placental markers of human exposure to polychlorinated dibenzofurans and polychlorinated biphenyls: Implications for Risk Assessment. *In: Complex Mixtures and Cancer Risk*. Vainio, H., Sorsa, M., and McMichael, A.J. (eds). IARC Scientific Publications, Lyon, pp. 55-64, 1990.
  34. Clark, G., Tritscher, A., Lucier, G., and Taylor M.: Dose-dependent increase in tumor necrosis factor-alpha production in TCDD exposed mice is Ah receptor dependent. *In: Organohalogen Compounds, Vol. 1: Dioxin '90-EPRI-Seminar, Toxicology, Environment, Food, Exposure-Risk*. Hutzinger, O., and Fiedler, H. (Eds.), Ecoinforma Press, Bayreuth, West Germany, pp. 77-88, 1990.
  35. Lucier, G., Tritscher, A., Goldsworthy, T., Foley, J., Clark, G., and Maronpot, R.: Role of estrogens in liver tumor promotion by TCDD in rats. *In: Organohalogen Compounds, Vol. 1: Dioxin '90-EPRI-Seminar, Toxicology, Environment, Food, Exposure-Risk*. Hutzinger, O., and Fiedler, H. (Eds.), Ecoinforma Press, Bayreuth, West Germany, pp. 107-110, 1990.
  36. Clark, G., Tritscher, A., Maronpot, R., Foley, J., and Lucier, G.: Tumor promotion by TCDD in female rats. *In: Banbury Report 35*. Cold Spring Harbor Laboratory Press, pp 389-404, 1991.
  37. Henderson, R. F., Sabourin, P. J., Medinsky, M. A., Birnbaum, L. S., and Lucier, G. W.: Benzene dosimetry in experimental animals: Relevance for risk assessment. *In: Relevance of Animal Studies to the Evaluation of Human Cancer Risk*. D'Amato, R., Slaga, T. J., Farland, W. H., and Henry, C. (Eds.), Wiley-Liss, Inc., pp. 93-105, 1992.
  38. Lucier, G. W.: Issues in risk assessment for sex hormones. *In: Hormonal Carcinogenesis*. Li, J.J., Nandi, S., and Li, S.A. (Eds.), Springer-Verlag, pp. 203-208, 1992.
  39. Lucier, G. W.: Receptor-mediated carcinogenesis. *In: Approaches to Classifying Carcinogens according to Mechanisms of Action*. International Agency for Research on Cancer. IARC Scientific Publications. 116: 87-114, 1992.
  40. Lucier, G.W., Clark, G., Tritscher, A., Foley, J., and Maronpot, R.: Mechanisms of dioxin tumor promotion: Implications for risk assessment. *Chemosphere*, 11: 177-180, 1992.
  41. Clark, G. C., Tritscher, A. M., Bell, D. A., and Lucier, G. W.: Integrative Approach for evaluating species and interindividual differences in responsiveness to dioxins and structural analogs. IARC Conference on Molecular Epidemiology, *Environ. Hlth. Perspect*, 98: 125- 132, 1992.
  42. Bell, D. A., Thompson, C. L., Taylor, J., Clark, G., Miller, C. R., Perera, F., Hsieh, L. L., and Lucier, G. W.: Genetic monitoring of human polymorphic cancer susceptibility genes

- by polymerase chain reaction: application to glutathione transferase mu. IARC Conference on Molecular Epidemiology, November 1991. *Environ. Hlth. Perspect.* 98: 113-117, 1992.
43. Bond, J. A., Wallace, L. A., Osterman-Golkar, S., Lucier, G. W., Buckpitt, A., and Henderson, R. F.: Symposium Overview--Assessment of exposure to pulmonary toxicants: use of biological markers. *Fundamental Appl. Toxicol.* 18: 161-174, 1992.
  44. Lucier, G. W., Portier, C., and Gallo, M. A.: Receptor mechanisms and dose-response models for the effects of dioxins. *Environ. Hlth. Perspect.* 101 (1): 36-45, 1993.
  45. Vanden Heuvel, J., and Lucier, G. W.: Environmental toxicology of polychlorinated dibenzodioxins and dibenzofurans. *Environ. Hlth. Perspect.* Vol. 100: 189-200, 1993.
  46. Lucier, G., Clark, G., Tritscher, A., Sewall, C., and Huff, J.: Carcinogenicity of TCDD in laboratory animals: implications for risk assessment. In: *Toxicology and Industrial Health*, Vol. 9, No. 4, 631-666, 1993.
  47. Melnick, R., Huff, J., Barrett, J. C., Maronpot, R., Lucier, G., and Portier C.: Cell proliferation and chemical carcinogenesis: Symposium overview. *Molecular Carcinogenesis*, 7: 135-138, 1993.
  48. Huff, J., Lucier, G., and Tritscher, A.: Carcinogenicity of TCDD: Experimental, mechanistic and epidemiologic evidence. *Annu. Rev. Pharmacol. Toxicol.*, 34: 343-372, 1994.
  49. Lucier, G.W.: Issues in toxicity testing for environmental chemicals and pharmaceuticals. In: *European Medicines Research: Perspectives in Pharmacotoxicology and Pharmacovigilance*. Fracchia, G.N. (Ed.), IOS Press, pp. 51-57, 1994.
  50. Tritscher, A. M., Clark, G. C., Vanden Heuvel, J. P., Kohn, M. C., Sewall, C. H., Portier, C. J., and Lucier, G. W.: Dose response effects of dioxins: species comparison and implication for risk assessment. In: *Dioxins and Health*. Schechter, A. (Ed.), Plenum Publishing Company, NY, pp. 227-247, 1994.
  51. Portier, C. J., Kohn, M. C., Sherman, C. D., and Lucier, G.: Modeling the number and size of hepatic focal lesions following exposure to 2,3,7,8-TCDD. *Organohalogen Compounds*, 21: 393-397, 1994.
  52. Portier, C., Lucier, G., and Edler, L. Risk from low dose exposures. Letter to the Editor, *Science*, 266: 1141-1142, 1994.
  53. Kohn, M. C., Lucier, G. W., Sewall, C. H., and Portier, C. J.: Physiological modeling of effects of TCDD on thyroid hormones in the rat. *Organohalogen Compounds*, 21: 223-226, 1994.

54. Lucier, G., Gallo, M., Portier, C., Bayard, S., Cooper, K., Georgopolous, P., McGrath, L., Andersen, M., DeVito, M., White, P., Kedderis, L., Mills, J., Silbergeld, E.: Dose response modeling. In: Health Assessment Document for 2,3,7,8-TCDD and Related Compounds. US EPA Document EPA/600/BP-92/001b, Washington, DC, 1994.
55. Kohn, M. C., Lucier, G. W., and Portier, C. J.; Receptor mechanisms and risk assessment. In: Hazardous Waste and Public Health: International Congress on the Health Effects of Hazardous Waste. Andrews, Jr., J. S., Frumkin, H., Johnson, B. L., Mehlman, M. A., Xintaras, S., and Bucsela, J. A. (Eds.), Princeton Scientific Publishing Company, NJ, pp. 421-432, 1994.
56. Sewall, C. H., and Lucier, G. W.: Dose-response and risk assessment considerations for receptor-mediated effects: Case study with a TCDD hepatic tumor promotion model. *Prog. Clin. Biol. Res.*, 387: 155-171, 1994.
57. Maronpot, R. R., Anna, C. H., Devereux, T. R., Lucier, G. W., Butterworth, B. E., and Anderson, M. W.: Considerations concerning the murine hepatocarcinogenicity of selected chlorinated hydrocarbons. In: Implications for Risk Assessment. Wiley-Liss, Inc., NY, pp. 305-323, 1995.
58. Demby, K.B., and Lucier, G.W.: Receptor-mediated carcinogenesis: The role of biological effect modeling for the risk assessment of dioxin and tamoxifen. In: Cellular and Molecular Mechanisms of Hormonal Carcinogenesis: Environmental Influences. Huff, J., Boyd, J., and Barrett, J.C. (Eds.), Wiley-Liss, Inc., NY, pp.113-129, 1996.
59. Lucier, G. W.: Mechanism-based toxicology in cancer risk assessment: Implications for research, regulation, and legislation. Meeting Report. In: *Environ. Health Perspect.* 104 (1): 84-86, 1996.
60. Sewall, C. H., Bell, D. A., Clark, G. C., Tritscher, A. M., Tully, D. B., Vanden Heuvel, J., and Lucier, G. W.: Induced gene transcription: Implications for biomarkers. Proceedings of the European Beckman Conference. *Clin. Chem.* 41 (12), 1829-1834, 1995.
61. Kavlock, R. J., Daston, G. P., DeRosa, C., Fenner-Crisp, P., Gray, L. E., Kaattari, S., Lucier, G., Luster, M., Mac, M. J., Maczka, C., Miller, R., Moore, J., Rolland, R., Scott, G., Sheehan, D. M., Sinks, T., and Tilson, H. A.: Research needs for the risk assessment of health and environmental effects of endocrine disruptors: A report of the U.S. EPA-sponsored workshop. *Environ. Health Perspect.* 104 (suppl. 4): 715-740, 1996.
62. Grassman, J., Clark, G., Yang, X-P., Masten, S., Spencer, D., Landi, M. T., Miller, C., Walker, N., and Lucier, G. Estimating variability in response to dioxin after exposure in Seveso, Italy. *Organohalogen Compounds* 30: 302-307, 1996.

63. Kohn, M. C., and Lucier, G. W.: Mechanism-based toxicology in cancer risk assessment: Biologically-based models. Proceedings of the Second World Congress on Alternatives and Animal Use in the Life Sciences. Zutphen, L. E. M., and Balls, M. (Eds.), Elsevier Press, pp. 617-625, 1997.
64. Lucier, G. W.: NTP's evolving strategies: The role of human studies. Risk Policy Report 4 (4): 27-31, 1997.
65. Lucier, G. W.: Issues for dose response evaluation of endocrine disrupting agents. Regulatory Toxicology 26: 34-36, 1997.
66. Grassman, J. A., Masten, S. A., Walker, N. J., and Lucier, G. W.: Animal models of human response to dioxins. Environ. Health Perspect. 106 (Suppl. 2): 761-775, 1998.
67. Jung, D., Berg, P. A., Edler, L., Ehrental, W., Fenner, D., Flesch-Janys, D., Huber, C., Klein, R., Koitka, C., Lucier, G., Manz, A., Muttray, A., Needham, L., Papke, O., Pietsch, M., Portier, C., Patterson, D., Prellwitz, W., Rose, D. M., Thews, A., and Konietzko, J.: Immunologic findings in workers formerly exposed to 2,3,7,8-tetrachlorodibenzo-p-dioxin and its congeners. Environ. Health Perspect. 106 (Suppl. 2): 689-695, 1998.
68. Reiter, L. W., DeRosa, C., Kavlock, R. J., Lucier, G. Mac, M. J., Melillo, J., Melnick, R. L., Sinks, T., and Walton, B. T.: The U.S. Federal framework for research on endocrine disruptors and an analysis of research programs supported during fiscal year 1996. Environ. Health Perspect. 106 (3): 105-113, 1998.
69. Melnick, R. L., and Lucier, G.: Endocrine disruptors. Proceedings of the Workshop on Emerging Environmental Challenges, California Environmental Protection Agency, Sacramento, CA, pp. 4.11-4.17, 1999.
70. Lucier, G. W., and Schecter, A. J.: Human exposure assessment and the National Toxicology Program. Environ. Health Perspect. 106(10): 623-628, 1998.
71. Bucher, J. R., and Lucier, G.: Current approaches toward chemical mixture studies at the National Institute of Environmental Health Sciences and National Toxicology Program. Environ. Health Perspect. 106(Suppl 6) 1295-1298, 1998.
72. Burkhart, J. G., Ankley, G., Bell, H., Carpenter, H., Fort, D., Gardiner, D., Gardner, H., Hale, R., Helgen, J. C., Jepson, P., Johnson, D., Lannoo, M., Lee, D., Lary, J., Levey, R., Magner, J., Meteyer, C., Shelby, M. D., and Lucier, G.: Strategies for assessing the implications of frog malformations for environmental and human health. Environ. Health Perspect. (In Press), 1998.
73. Matthews, H. B., Lucier, G. W., and Fisher K. D.: Medicinal herbs in the United States: Research needs. Environ. Health Perspect. 107: 773-778, 1999.

74. Paules, R. S., Tennant, R. W., Barrett, J. C., and Lucier, G. W.: Bringing genomics into risk analysis: The promises and problems. Risk Policy Report (In Press), 1999.

EDITORIALS

1. Hook, G. E. R., and Lucier, G. W.: Welcome to the new Environmental Health Perspectives. *Environ. Health Perspect.* 101 (1): 6, 1993.
2. Lucier, G. W.: Risk assessment: Good science for good decisions. *Environ. Health Perspect.* 101 (5): 366, 1993.
3. Hook, G. E. R., and Lucier, G. W.: EHP: Review and rededication. *Environ. Health Perspect.* 102 (4): 346, 1994.
4. Lucier, G. W.: Not your average Joe. *Environ. Health Perspect.* 103 (1): 10, 1995.
5. Hook, G. E. R., and Lucier, G. W.: Anniversaries and attitudes. *Environ. Health Perspect.* 105 (4): 360, 1997.
6. Hook, G. E. R., and Lucier, G. W.: Synergy, antagonism, and scientific process. *Environ. Health Perspect.* 105 (8): 784, 1997.
7. Hook, G. E. R. and Lucier, G. W.: Environmental Health Information Service. *Environ. Health Perspect.* 105 (10): 1028, 1997.
8. Lucier, G. W. and Needham, L.: Exposure assessment: the neglected component of risk assessment. *Environmental Health Letter*, 1998.
9. Hook, G. E. R., and Lucier, G. W.: Cautionary reflections. *Environ. Health Perspect.* 106 (4): 168, 1998.
10. Lucier, G. W. and Barrett, J. C.: Public health policy and the National Toxicology Program. *Environ. Health Perspect.* 106 (10): 470, 1998.
11. Hook, G. E., and Lucier, G. W.: Preparing for the new millennium. *Environ. Health Perspect.* 107(4): p. A180, 1999.
12. Lucier, G. W.: Why not use it all? *Environ. Health Perspect.* 107(5): p. A232-3, 1999.